

FREEDOM'S *Phoenix*



Featured Articles

Pg 3 Freedom's Phoenix Tutorial - Nick Barnett - FreedomsPhoenix Digital Magazine viewing tips

Pg 4 Anthony Gregory - Sustainable Living, Liberty, and the Pursuit of Urban Farms

Pg 7 Charles Goyette - The Command Economy

Pg 8 Tom DeWeese - Agenda 21 and the destruction of American liberty

Pg 12 Rosa Koire - WHAT IS UNITED NATIONS AGENDA 21?

Pg 14 Powell Gammill - General Considerations in Fruit, Nut and Vegetable Production (Part 1)

Pg 21 Powell Gammill - The Garden Pool: A subterranean aquaponics greenhouse

Pg 24 Pam Perry - Independence Through Gardening

Pg 28 Barbara Peterson - The Garden Room – Gardening for Life

Pg 30 Gary and Verda Gagnon - Prepping with an Urban Garden

Pg 33 Open Source Ecology

Pg 34 Global Village Construction Set

Pg 40 Rosa Koire - The Three Cornerstones of UN Agenda 21/ Sustainable - Development are Economy, Ecology, and Social Equity.

Pg 41 William Buppert - Unlimited Debt

Pg 42 Daniel Taylor - The Scientific Dictatorship Explained

Pg 45 SARTRE - Agenda 21 in New York State - Home Rule and ArticleX

Pg 47 SARTRE - Sustainability in All Things except Rational Thinking

Pg 49 Donna Hancock's How To Start Your Garden/Mini-Farm

Pg 57 Donna Hancock - GOT CHICKENS?

Pg 61 Donna Hancock's How To Start Your Garden/Mini-Farm - Video

Pg 62 Donna Hancock - JUICING TO STAY HEALTHY

Pg 64 Donna Hancock - HOMEMADE GOAT CHEESE...

Pg 66 L.E. Stone - The Case Against Quartzsite

Pg 70 Chip Saunders - THE MONTH IN GUNS

Pg 75 Real Gardens for Real People

Pg 76 Wonder Soil

Pg 78 "22 Reasons" A Testimonial about Wonder Soil

Pg 79 4409 - FRUIT POLICE SHOWDOWN

Pg 80 Bill Domenico - LASER GRAFFITI ACTIVISIM

Pg 85 Ernest Hancock - Publisher's Backpage



SUBSCRIBE NOW!

(CHECK OUT OUR SILVER PACKAGE)

Credits:

Editor-In-Chief
Sierra Hancock

Publisher
Ernest Hancock

Technical Advisor
Nick Barnett

Illustrator
Scott Bieser

Webmaster
FreedomsPhoenix.com
Tyger Gilbert

Contact Us :

FreedomsPhoenix.com

The domain and name of FreedomsPhoenix are servicemarks of Ernest Hancock. All rights reserved worldwide. Feature articles, columns, artwork and illustrations should be examined to determine the copyright status claimed by each individual creator.

Ernest Hancock
4886 W Port Au Prince Lane
Glendale, AZ 85306 USA.

PERMISSION is Granted to Forward this magazine in its entirety.



Freedom's Phoenix Digital Magazine viewing tips

By Nick Barnett

(For continuous updates to enhance your digital magazine experience use links below)

[Make a Comment](#) • [Email Link](#) • [Send Letter to Editor](#) • [Save Link](#)

[iPad/iPhone](#)

[SmartPhone](#)

[Andriod Device](#)

[Other](#)



The Freedom's Phoenix digital magazine has been optimized and tested for use on the iPad with the "GoodReader" application. Since Apple's products do not have native support for interactive publications, you have to purchase the application from the iTunes digital download store. You can either follow [this link](#) to be taken to the application purchase page or use your iPad's AppStore and search for "GoodReader."



Once GoodReader is installed, you can optimize your digital magazine experience by changing a few default options in the application. Launch GoodReader and click the settings icon (it looks like a little gear in the bottom left of the screen). In the "General Settings" tab, it is recommended that you set the "Asks for link action" option to OFF. In the "PDF files" tab, you should ensure that "Horizontal swipe" is set to ON, and "Fit page to width (portrait)" is set to ON.

Once you have made the above changes, you will be able to swipe left and right to "flip" through the digital pages and the pages should appear as intended, just like a real paper magazine, but with modern paperless interactivity.

To obtain the Freedom's Phoenix digital magazine, launch GoodReader and click "Browse the Web." To get to this option, you may need to expand the "Web Downloads" sub-window found on the right hand column of the application. When you click "Browse the web" you

will be presented with GoodReader's internal web browser, just type in www.freedomsphoenix.com in the address bar and hit "Go" on your iPad onscreen keyboard.

Once Freedom's Phoenix has loaded, click on "Magazine/Radio/TV" in the website's navigation bar, then choose the option for "Online Magazine List." You may be prompted to enter your Freedom's Phoenix username and password at this point. Choose the digital magazine you wish to download and you will be taken to a page with a link that says "Download Magazine File." Once you click this, GoodReader will begin downloading the file. Once the file has finished downloading, you will be able to access it from the "Recent Downloads" menu in the "My Documents" screen of GoodReader.



The best software for all [android devices](#) so far has been the FREE software from the Andriod Market: [ezPDF Reader](#)

[Make a Comment](#) • [Email Link](#)
[Send Letter to Editor](#) • [Save Link](#)



Sustainable Living, Liberty, and the Pursuit of Urban Farms

By Anthony Gregory

[Make a Comment](#) • [Email Link](#) • [Send Letter to Editor](#) • [Save Link](#)



IN Oakland, California, where I live, urban homesteading—growing food on private land for small-scale trade and consumption—has become so common the city government has backed off a bit. In a rare triumph for sanity

and freedom, anachronistic zoning ordinances from 1965 are being liberalized to accommodate the city farmers. [Molly Samuel writes at KQED:](#)

“The city has already made some changes; it’s now legal to grow and sell vegetables on an empty lot with a conditional use permit. . . . Oakland North reports one of the hotly debated topics [at a city meeting] was animal husbandry: Should Oaklanders be permitted to raise, slaughter, and sell animals? Or not?”

Despite the remaining government bureaucracy, we have to cheer on the homesteaders. They are so impossible to ignore, hundreds of them flooding a city meeting, that the tyranny of zoning is being ratcheted back for once.

And although it has a leftish quality, libertarians ought to take notice of this countercultural movement, whose localizing agenda poses profound implications for the future of liberty. With the economic forecasts dire and the corporatist system of mega-farms firmly gripping the Obama administration and all federal politics for the foreseeable future, our rights and perhaps very lives may depend on the freedom to farm at home.

Libertarians often straddle radically different, sometimes seemingly opposed, stereotypes. We are simultaneously atomist rugged individualists and slaves to the anonymous division of labor found in modern cosmopolitanism. This seeming paradox is reconciled in our simultaneous love of political localism and integrated economics, self-sufficiency and the contemporary blessings of a thriving voluntary community. And as admirers of both the frontier and the integrated city life, we can see much to relate to in the urban homesteaders and their hybrid lifestyle of city-slicking, strenuous agrarianism.

The urban farmers too suffer from being pigeonholed as the type you’d find in quasi-socialist hippie communes. Their community’s language and cultural habits can be jarring to a free market radical, but they need not be as dissonant as

they first sound. When a Randian hears the term “sustainable living”—another common theme in urban homesteading—he might first think of the central planning-nightmare called “sustainable development” or EPA-mandated encumbrances on his beautiful track-housing, when we can as plausibly interpret the meaning to be: “freedom from the vagaries of the public utilities system and state-subsidized mass agriculture.”

Even in the larger sustainable living communities, we see a diversity of social organization. “Most cohousing communities with gardens use organic gardening practices, but just as the culture of cohousing groups varies widely, organizing and running a cohousing garden is a highly individualized project,” writes Jenise Aminoff in the Fall 2010 issue of *Urban Farm* magazine. Indeed, while voluntary communalism is totally compatible with libertarianism, even shameless capitalists can find much to love. Eno Commons, “a suburban cohousing community on the outskirts of Durham, N.C.,” initially ran its “garden on a standard allotment model, where each unit was assigned a garden plot,” but this led to problems: “there was a disconnect between a small handful of people doing work but the whole community picking,” explains garden manager Katherine Lee. And so what did they do? Aminoff explains:

“Last fall, Lee proposed a radical change: a market model. With Lee as the manager doing most of the gardening work, residents now pay for their garden produce. On the night of the community’s weekly common meal, Lee harvests the garden’s produce and brings it ‘to market’ in the common house.”

Surely, most other approaches to communal gardening involve a bit less commercial exchange, but from a quarter-acre urban homestead or an integrated sustainable living community to a produce co-op and the farmers’ markets that have gloriously emerged in every major city, we see there is no conflict between the market economy and sustainable farming in a municipal context. The way of life is no less libertarian than living in a condo or homeownership association.

Urban Farms vs. the State

What *are* in conflict, however, are sustainable living and city pastures on the one hand with the agricultural bureaucracy on the other—the USDA, the farm subsidies, the police-state crackdowns on small independent farms pro-

Continues on Page 5

Continued from Page 4 - Sustainable Living, Liberty, and the Pursuit of Urban Farms

ducing and selling raw milk and other such glorious and healthy products.

Even the mildest displays of homegrown produce have run into legal trouble. In July news traveled fast of the plight of Julie Bass of Oak Park, Michigan, who was threatened with 93 days of jail time for the crime of planting vegetables in her front yard. A mere five raised beds featuring corn, tomatoes, squash and other vegetables constituted her great offense. Amid a massive public uproar, the city dropped the charges. In most areas of everyday life, the state has become ever more intrusive and invasive. On growing our own food, however, Americans appear sick of being on the defensive. The mainstream adoption of urban homesteading can lead to one of the great retrenchments of state power and influence in our times, echoing the homeschooling movement that has grown so impressively in recent years.

Much of the urban farm movement can be traced to the World War-era victory gardens—what we might call a market response to a statist emergency. The phenomenon of growing your own food (among other consumables) took off in the 1960s and 1970s and is now back in the cities, taking them by storm. Once again, they are coming in response to institutional crisis. In cities suffering in every other way, urban farms might save the day. The Detroit Agriculture Network's Kristine Hahn points to the city's "113 community gardens. . . , 18 school gardens, and 220 family gardens" as signs of hope for that suffering city's future, [writes Elizabeth Wahl](#).

It is a global phenomenon: The USDA estimates that urban areas grow about 15 percent of the food worldwide. In some countries, socialist regimentation has made private gardens absolutely necessary for survival. The Soviet government's attempts to feed the masses were infamously disastrous, particularly in the calamitous era of Lyskensoism from the 1920s to early 1960s, when the Russian government imposed bizarre standards of agriculture along "proletarian" lines—the forced collectivization of farming and the rejection of genetics and mainstream botanical practices as being based in bourgeois pseudo-science. As the government began looking the other way, its citizens were finally able to feed themselves. By the late Soviet era, 90% of the nation's fresh vegetables and a good deal of its animal products were from "unofficial sources"—" meaning *dacha* gardens and the small private plots that collective farmers were permitted to work in their spare time," according to the Christian Science Monitor. These private gardens became crucial in the post-Soviet upheaval as well. A 2008 survey conducted by the Public Opinion Fund found that 56% of urban Russians had a *dacha* or "kitchen garden." The American government is still not as dysfunctional as Russia's but the laws of economics apply universally. Should another financial collapse come, American *dachas* could be our lifeline.

At least implicitly distrustful of Washington, the urban homesteading movement gets bigger every day. With bigness, however, comes the threat of politicization, and in particular the threat of these farms being harvested by government, the co-ops being co-opted by the state. As with the bureaucratic nationalization of the word "organic," the voluntarism of sustainable

living may one day be supplanted by regimented control and corporatism.

A Diversity of Meanings and Conflicts

A hint at one might come, and how urban homesteaders, without some guidance on the ethics of liberty, might make themselves vulnerable to a corporate-state takeover, arrives in the story of a trademark skirmish from this February. The Dervaeas Institute, an organizational arm of the Dervaeas family well known throughout the community for its pioneering work, its respected farm in Pasadena, and its website [UrbanHomesteading.com](#), sent out cease and dissent letters to sixteen groups warning them about their appropriation of the term "Urban Homesteading." According to Jess Watson, writing in the Summer 2011 edition of *Edible East Bay*, the letters immediately resulted in "the Facebook pages of IUH, the Denver Institute of Urban Homesteading (a farmers market), and several homesteading-related books [being] taken down."

According to a Dervaeas press release, their cease and desist letters were only meant to inform the sixteen organizations of "the proper usage of the registered terms. No threat was made against anyone's first amendment rights; yet, there has been a heated argument in the media against what should have been the Dervaeases' normal rights to protect their trademarks."

But perhaps "normal rights" must be rethought if they involve controlling how others use such a phrase as "urban homesteading." Libertarians have unique insights on intellectual property's incompatibility with traditional property rights, and maybe some radical free market thought is what this community needs. There is also the practical consideration: "Urban homesteading" yields 610,000 finds on Google. Some entries concern not just sustainable farming but actual homesteading—squatting on seemingly unclaimed property. This squatting can be both farm-related and libertarian: with the state neglecting huge swaths of so-called "public property," community farming can be an act of revolutionary Lockeanism.

In 2006, the city government moved in to seize a plot of public land that had been effectively homesteaded by 350 farming families in central Los Angeles. The city had caved to public pressure not to place a garbage incinerator there in 1987. "The lot remained abandoned for seven more years, when [around 1994] working folks from the neighborhood set up on the unused land, established gardens and cultivated the land in the lot," [writes libertarian blogger Charles Johnson](#). Ten years after they began homesteading the lot, the city sold it to a wealthy businessman who had owned a fraction of it before it was stolen by the government through eminent domain in the 1980s.

Thankfully, most urban homesteads simply involve city farming and sustainable living practices that rest comfortably on private land that isn't disputed, putting aside the invasive limitations of zoning law. "Urban homesteading" can also refer to government programs of home ownership—this is of the least interest to the libertarian. Given all these various meanings of "urban homesteading," perhaps we ought to reject the whole notion of controlling the term

Continues on Page 6

Continued from Page 5 - Sustainable Living, Liberty, and the Pursuit of Urban Farms

through intellectual property law.

We Must Cultivate Our Garden

The trademark heat did not deter Ruby Blume, a recipient of one of the letters, from moving ahead with the book she helped Rachel Kaplan write. Skyhorse publishing this year printed *Urban Homesteading: Heirloom Skills for Sustainable Living*, a little manifesto that explores the principles of permaculture, gardening methods, the intimate bond between what we grow and what we eat, and how to build sustainable homes. The politics, economics, and environmental values that creep in the text might be a bit hard for a libertarian to take, but there are a few insights we can relate to:

“If we wait for government action before jumping on board, it will be too late. Change like this has to begin. In Congress. In the boardroom. In your home. You only have control over one of those things. Exert it.” (p. 9)

Indeed, today’s urban homesteaders are acting directly, taking responsibility in their own sphere of influence, to improve their lives and escape the limitations of the state-infested world—and they do so without isolating themselves, but rather by expanding upon their ties to their community.

Kaplan and Blume give a sense of the individualism of this movement, one not necessarily loyal to enviro-leftist conformity. San Francisco permaculture teacher Kevin Bayuk is quoted with something mightily similar, in substance if not tone, to one of my favorite George Carlin routines on the futility of trying to “save the planet”:

“I’ve seen people approach this type of lifestyle or message as something they must do. Climate change, species extinction! Do something now! We must! I’ve had those feelings of urgency, but when people approach this kind of lifestyle with a sense of [urgency], it’s just a

few years before burnout. That type of energy leads directly to failure; it doesn’t fit with the economy of a healthy system. I advocate for a different metaphor for why you’d live like this. I remember a story that comes from science that says the G-type star we’re flying around on is five or six billion years old, and it might live another twelve billion years. If humanity makes it, twelve billion years down the road all the hydrogen will have fused into helium in that star and it’s going to erupt and expand and envelop the Earth and all the life on it will be gone. In this story, you can’t save the Earth or humanity, so there’s no must about it. The story’s written; it’s just a matter of time. Is it twelve billion years from now, fifteen years from now, 100 years from now? It doesn’t matter to me; I just know the story of trying to ‘save’ the Earth is foolish.” (p. 20)

In the long run, we’re all dead, said Keynes. Nevertheless, the Austrian school of economics to which I subscribe suggests we should think about the future, at least as far as we can see ahead. With a financial system in tatters, utility systems poorly maintained and due for a major disaster, a government neither inclined nor able to handle emergencies natural or manmade, and a corporatist food system bringing us continually lower quality sustenance at ever higher prices, the state-approved way of life can sometimes appear to be a race to the bottom. For the sake of surviving, to say nothing of protecting our freedom from the state, those of us who have yet committed to a flight from the cities must begin taking urban homesteading seriously. Meanwhile, those already in that movement, disenfranchised from the nationalist system and thriving as a growing, localized economic force, need to hear about the intellectual revolution of peace, voluntary economics, and liberty known as libertarianism. It’s a match made in heaven. Let the courting process begin.

* Thanks to Nicole Booz for her help and inspiration on this article. 🍷

[Make a Comment](#) • [Email Link](#)
[Send Letter to Editor](#) • [Save Link](#)

The Command Economy

By Charles Goyette

[Make a Comment](#) • [Email Link](#) • [Send Letter to Editor](#) • [Save Link](#)



AMERICA is transforming itself, without forethought, debate, or pause, into a command economy. A command economy is a top-down, state-controlled economy directed by planners and bureaucrats, boards and bodies, administrators and authorities. A command economy is not characterized by mutuality of interest and agreement between parties. It relies on edict. A command economy, as the name implies, orders the affairs of a nation by coercion. In a free economy goods and services are bought and sold by consent; business transactions are based on agreement; contracts depend upon a meeting of the minds of the parties involved. In a command economy government sets prices, controls and directs resources, and oversees production and consumption. Free economies produce prosperity; command economies produce poverty. The transformation of America is already taking place at breakneck speed, even before the current economic crisis is full blown. Historical precedents insist that as conditions worsen, the transformation into a command economy will accelerate.

It is astonishing that this should be taking place, especially at a time in which three billion people around the globe have rejected the poverty, want and shortages of their command economies to begin the experience and blessings of abundance. It is not as though object lessons are wanting. China's stunning economic growth, its modernization and rising living standards are the result of nothing more complicated than freeing the command economy. Although lessons abound, Americans are choosing – or perhaps failing to choose and therefore letting the choice be made for them – to go in much the same direction as the command economy of postwar Great Britain. That period saw the nationalization of entire sectors of the British economy, a currency crisis and prolonged economic decline including crippling unemployment and choking inflation. The reasons that the United States would choose to follow a pattern that hollows out economies the way it did the British are many. But as a symptom, although not a cause of this self-inflicted harm, look to the modern American politician. For today's breed of politician, power is their very passion. Their every concern and the entire public debate about politicians centers around the use of power. How may power best be exploited and aggrandized? Who is to be bailed out, who is to be plundered to pay for it? Who is to be subsidized, who penalized? Who shall be taxed and who shall be paid? In contrast, the founders looked upon power very differently: How can it be kept in check? In yielding to the former and to their command economy, the current generation of Americans, blessed with so much, will be the shame of the ages.

Anyone believing the evidence for the looming command economy is being overstated need look no further than the speed at which American finance has been nationalized in the current crisis. Legislators voted an initial \$700 billion bailout package, but in no time the taxpayers ended up with more than eighteen times that, \$12.8 trillion in loans, spending, and guarantees. And to make clear who is really in charge, the giveaways are accompanied by a refusal of the authorities to disclose who is getting what and what kind of collateral, if any, is being given. The trend was dramatically illustrated in October 2008. In a development that played out like

a scene from *The Godfather*, the CEOs of the nine largest banks in America, dealmakers and negotiators in their right, were ushered into a room at the Treasury Department in Washington and handed a one-page document agreeing to sell preferred shares to the government. They were told by Henry Paulson, according to the *New York Times* account, that they must sign it before leaving. The chairman of Wells Fargo protested that his institution didn't have problems with toxic mortgages and didn't need a bailout. Too bad. "It was a take it or take it offer," said one insider. An online writer for *The Wall Street Journal* favorably likened Paulson's commandeering of the banks to Reagan at the Berlin Wall. "History often carries an air of inevitability," he gushed.

If there is inevitability to America's becoming a command economy, it is a sorrowful day for human freedom. The Central Plan of the command economy is incompatible with dissent, disagreement, individual preferences, and your own plan, whatever it may be. If the Central Plan is to prevent foreclosures on homeowners who can't pay, then the plans of individuals whose resources will be used to prevent those foreclosures must give way. If your individual plan and the Central Plan are in conflict, you will have to give up your plan. As we have noted, a free economy rests on agreement, but a command economy is constructed of coercion. One of the reasons (among many to which I refer in my book *The Dollar Meltdown*) that a command economy produces poverty has to do with the diversion of productive human effort. In a free economy people provide services that are sought by others and they are rewarded for doing so. Each individual's own wants and needs are met to the extent he finds ways to serve others. But in a command economy enormous amounts of human effort are expended in attempts to influence or control the Central Plan. This activity produces no new wealth. It only seeks to divide what wealth already exists.

The command economy is not the exclusive province of either the left or the right, Republican or Democrat, Communist or Fascist, Stalinist or Nazi, Pol Pot, Mao, Chávez, or Ahmadinejad. It is what they all have in common. Just as war is the health of the state, economic turbulence is the state's opportunity for self-advancement. As the unseen and destructive consequences of each new command and initiative unfold, new plans are created and commands issued to undo the latest harm. In the current sequence, the Fed used its monetary monopoly to create artificial credit conditions; the cheap money fueled a housing boom, which, like all bubbles, popped; the monetary and fiscal authorities rushed in to bail out the banks; the only means they have of bailing out the banks is to borrow or print more money

Charles Goyette is the author of the New York Times bestseller *The Dollar Meltdown: Surviving the Impending Currency Crisis with Gold, Oil, and other Unconventional Investments*. This article is an excerpt from *The Dollar Meltdown*.

[Make a Comment](#) • [Email Link](#)
[Send Letter to Editor](#) • [Save Link](#)

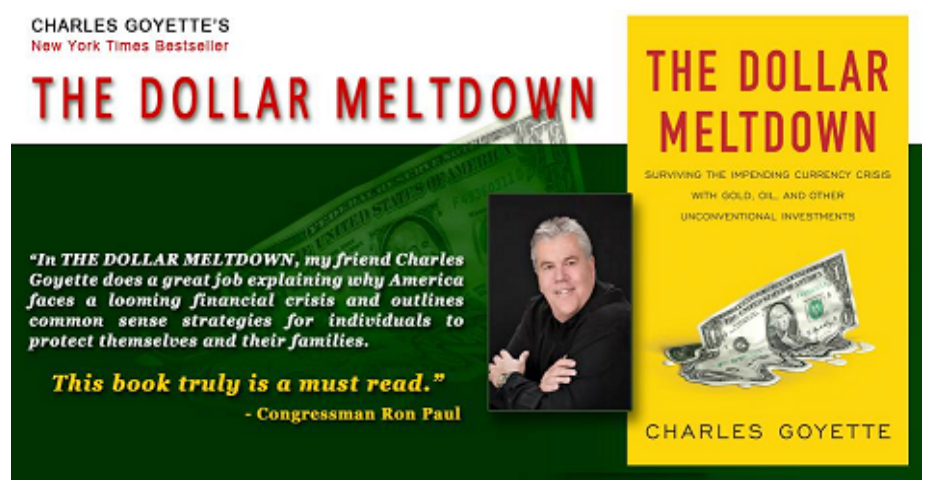

Agenda 21 and the destruction of American liberty

By Tom DeWeese

[Make a Comment](#) • [Email Link](#) • [Send Letter to Editor](#) • [Save Link](#)



DURING the Cold War, communists tried to get us to surrender our liberties and way of life for the wisdom of Karl Marx. Americans didn't buy it.

But now, they have taken the same clap trap and wrapped it all in a

nice green blanket, scaring us with horror stories about the human destruction of the environment – and so we are now throwing our liberties on the bon fire like a good old fashioned book burning -- all in the name of protecting the planet.

It sounds so friendly. So meaningful. So urgent. But, the devastation to our liberty and way of life is the same as if Lenin himself had ordered it.

The root of this transformation of our once-free society can be clearly traced to a very specific event and to a specific document resulting in a very destructive policy -- a UN document called Agenda 21, first revealed at the UN's Earth Summit in 1992. The working name of the policy is Sustainable Development.

While most have been told that Sustainable Development is just about conservation and management, it is really a code word for an entire economic and social agenda. Rather than good management of resources, Sustainable Development has come to mean denied use and resources locked away from human hands.

Interestingly, it is not a Republican or Democrat issue. It's not liberal or conservative. It is being implemented on a purely bipartisan basis.

It is the official policy of the federal government, every state government, and nearly every city, town and county in the nation, all done under the excuse of reducing our carbon foot print to prevent global warming that scientists now dispute even exists.

To enforce the policy, a new language taking over government. The typical city council meeting discusses "comprehensive development," "density," "historic preservation," and "partnerships" between the city and private business. Civic leaders organize community meetings run by "facilitators," as they outline a "vision" for the town, enforced by "consensus."

Free trade, social justice, consensus, carbon footprints, partnerships, preservation, stakeholders, land use, environmental protection, development, diversity, visioning, open space, heritage, comprehensive planning, critical thinking, and community service are all part of our new language.

The term "Sustainable Development" was born on the pages of a United Nations document called "Our Common Future," the official report of the 1987 UN World Commission on Environment and Development.

As a result of this report, for the first time, the use of environmental protection and human development were tied to the age-old Socialist goals of international redistribution of wealth. And that is the key to understanding the true purpose of Sustainable Development and all of its policies -- control of all facets of the economy.

At the 1992 Rio Earth Summit, President George H. W. Bush, in signing the document, committed the US to implement the policies of Agenda 21. In 1996, President Bill Clinton, in compliance with Agenda 21, created the President's Council on Sustainable Development. The purpose of the President's Council's was to translate the guidelines of Agenda 21 into public policy to be administered by the federal government.

And that has become the "ruling authority" through which a UN plan (Agenda 21) has become unquestioned US policy throughout the nation.

Still, we are told by proponents that Sustainable Development is nothing more than good environmental stewardship. And that it is locally driven. To accept that is a serious and dangerous mistake

What is Sustainable Development?

Regardless of what local planning groups tell you, Sustainable Development is about a planned central economy and redistribution of the wealth – on a local, state, national and international level.

The process by which it is implemented creates a matrix of locked away land -- or severe land use controls; control of energy and energy production; control of transportation; control of industry; control of food production; control of development; control of water availability; and control of population size and growth.

Agenda 21 is not just policy – it is a complete system to change the way we think, the way we react, the way we make decisions – and those who promote it have very specific answers as to how they want each of you to do those things – it's called behavior modification. That's why they call it an AGENDA.

The Three Es

The Sustainable Development logo used in most literature on the subject contains three connecting circles labeled **Social Equity; Economic Prosperity; and Ecological Integrity** (known commonly as the 3 Es).

Social Equity

Social Equity is based on a demand for "social justice," described as the right and opportunity of all people "to benefit equally from the resources afforded us by society and the environment." – Redistribution of the wealth. Karl Marx was the first to coin the phrase "social justice." The Sustainablist system is based on the principle that individuals must give up selfish wants for the needs of the common good, or the "community."

This is the same policy behind the push to eliminate our nation's borders to allow the "migration" of those from other nations into the United States to share our individually-created wealth and our taxpayers-paid government social programs. Borders, they say, stop the natural migration of the human race. "National sovereignty" they say, "is a social injustice."

According to the Sustainablists it is a social injustice for some to have prosperity if others do not. It is an accepted concept of Sustainable Development that private property is an evil that is

Continues on Page 9

Continued from Page 8 - Agenda 21 and the destruction of American liberty

used simply to create wealth for a few.

As a result, Social Equity through Sustainable Development is a means to a forced utopia with promises of healthcare for all. Jobs for all. Housing for all. Equality for all.

So, the reason the government refuses to secure our borders is because it is committed to imposing sustainable development.

The reason Congress refused to listen to your pleas against centralized health care is because it is committed to sustainable development.

The reason our local governments are imposing redevelopment and comprehensive development plans that include mixed use and low income public housing projects, forced open space and restrictions and controls on energy and water and population growth is because of the trickle down enforcement of sustainable development.

This is why we say that Sustainable Development is at the root of literally all other issues we are fighting.

Economic Prosperity

Sustainable Development's economic policy is based on one overriding premise: that the wealth of the world was made at the expense of the poor. It dictates that, if the conditions of the poor are to be improved, wealth must first be taken from the rich.

The international system of Agenda 21 encompasses the free trade movement that created the North American Free Trade Agreement (NAFTA), and Public/Private Partnerships, all pulled together into a government-driven economy called "corporatism."

It is not Capitalism or free markets, though it may have some of the trappings. The marketplace is still there. But, ultimately, corporatism does not trust the marketplace to do what the elites want done.

The partnerships allow for special tax breaks; access to land for some developers but not others; non-compete clauses in government projects that guarantee profits, access to grants and lucrative special government projects, and much more.

Corporations that play ball get the power of government -- and Government gets to hide behind the independence of private business. Thus the partnership between corporations and government is done at the expense of ordinary people -- the exact opposite effect of free markets controlled by consumers.

This is the new way business is being run in America under Sustainable Development. It's certainly not free enterprise or open markets. The true description is government-sanctioned monopolies, right out of the Mussolini fascist play book.

Ecological Integrity

To understand the power of the transformation of society under sustainable development, consider this quote from the UN's Biodiversity treaty which was also introduced at the 1992 Earth Summit:

"Nature has an integral set of different values (cultural, spiritual and material) where humans are one strand in nature's web and all living creatures are considered equal. There-

fore the natural way is the right way and human activities should be molded along nature's rhythms."

This quote lays down the ground rules for the entire Sustainable Development agenda. It says humans are nothing special -- just one strand in the nature of things or, put another way, humans are simply biological resources.

Sustainablist policy is to oversee any issue in which man interacts with nature --which, of course, is literally everything. This is necessary, Sustainablists say, because humans only defile nature. In other words, Sustainablists view man as nothing more than a swarm of locusts which swoops down on nature and sucks it clean until there is nothing left. Nothing good comes from man, according to Sustainablist doctrine.

And private property ownership and control is a main target of Sustainable Development. Consider this quote from the report of the 1976 UN's Habitat I conference which said: *"Land ...cannot be treated as an ordinary asset, controlled by individuals and subject to the pressures and inefficiencies of the market. Private land ownership is also a principle instrument of accumulation and concentration of wealth, therefore, contributes to social injustice."*

The fact is, Agenda 21 is a blueprint to completely change our society to a top-down planned central economy in a strange mixture of Socialism, fascism and corporatism.

To convince Americans to accept it required something that would get us to sacrifice our natural rights voluntarily. The answer was environmental Armageddon. You must sacrifice freedom to protect the planet. It's urgent we're told.

Consider this quote by Alexander King, co-founder of the Club of Rome: *"In searching for a new enemy to unite us, we came up with the idea that pollution, the threat of global warming. Water shortages, famine and the like would fit the bill...All of these dangers are caused by human intervention...the real enemy then, is humanity."*

So the urgency is on. Global warming and Climate Change are feeding the hysteria. There's no time to consider things like individual concerns, wants and needs. Selfish, cries the Sustainablist! We must save the environment! Go Green! Get out of your cars. Stop using energy. Sacrifice. Cut your carbon foot print or perish.

Federal and state governments, working hand in hand with a hoard of Non-governmental organizations -- private groups with personal political agendas, force passage of rules and regulations--passed down to local communities.

But, say your local officials, none of that UN, socialist stuff is true -- just conspiracy theories by right wing radicals. Again, consider this quote from J. Gary Lawrence, a planner for the city of Seattle, and an advisor to the President's Council for Sustainable Development: *"Participating in a U.N. advocated planning process would very likely bring out many...who would actively work to defeat any elected official...undertaking Local Agenda 21. So we will call our process something else, such as "comprehensive planning," "growth management," or "smart growth."* Local indeed.

Sustainable Development is the process by which America is being reorganized around a central principle of state collectivism using the environment as bait. This is a political movement led by those who seek to control the world

Continues on Page 10

Continued from Page 9 - Agenda 21 and the destruction of American liberty

economy, dictate development and redistribute the world's wealth. They use the philosophical base of Karl Marx, the tactics of Adolph Hitler, and the rhetoric of the Sierra Club.

Everything connected with Sustainable Development translates to higher costs, shortages and sacrifice. The best way to understand what Sustainable Development actually is can be found by discovering what is NOT sustainable.

Maurice Strong, Secretary General of the UN's Rio Earth Summit in 1992 said, "...*Current lifestyles and consumption patterns of the affluent middle class – involving high meat intake, use of fossil fuels, appliances, home and work air-conditioning, and suburban housing are not sustainable.*"

Four routes to Agenda 21

So how is this wrenching transformation being put into place? There are four very specific routes being used. In the rural areas it's called the Wildlands Project. In the cities it's called smart growth. In business it's called Public/Private Partnerships. And in government it's called stakeholder councils and non-elected boards and regional government – or reinvented government.

The Wildlands Project was the brainchild of Earth First's Dave Foreman and it literally calls for the "re-wilding" of 50% of all the land in every state – back to the way it was before Christopher Columbus set foot on this land.

In 1983, when Foreman first dreamed up the scheme, he said: "*It is not enough to preserve the roadless, undeveloped country remaining. We must re-create wilderness in large regions: move out the cars and civilized people, dismantle the roads and dams, reclaim the plowed lands and clearcuts,-- reintroduce extirpated species.*" Destruction of human civilization was his goal. In reality, The Wildlands Project is a diabolical plan to herd people off the rural lands and into human settlements.

From the demented mind of Foreman, the plan became the blueprint for the UN's Biodiversity Treaty. So now the scheme is international in scope – with the power of law.

Thomas Lovejoy, a science advisor to the federal Department of Interior said, "*We will map the whole nation...determine development for the whole country, and regulate it.*"

Yet, local officials are quick to deny that such ideas have their origins on the international level. They accuse me of wearing a tin foil hat and hearing voices.

Well, here is a voice I hear. Again, Maurice Strong said at the UN's Earth Summit, "*Isn't the only hope for the planet that the industrial nations collapse? Isn't it our responsibility to bring that about?*" And that is the true agenda we face!

But how do you remove people from the land? One step at a time.

- Deny grazing and water rights on public lands. It becomes more difficult and more expensive to run the farm or ranch – eventually he goes out of business.

- Lock away natural resources by creating more national parks. It shuts down the mines -- and they go out of business.

- Call every mosquito infested swamp and occasional mud puddle a wetlands and ban any development around it.

- Invent a Spotted Owl shortage and pretend it can't live in a forest where timber is cut. Shut off the forest. Then, when no trees are cut, there's nothing to feed the mills and then there are no jobs, and -- they go out of business.

- The state of Maryland is considering a plan to ban septic tanks as a means to protect the Chesapeake Bay, even though there is no evidence that septic tanks do any damage what so ever. The only result of the ban will be to make it impossible to live in a rural area – unless you want to spend several million dollars on a private water treatment plant.

Each of these programs is designed to make it just a little harder to live on the land – a little more expensive – a little more hopeless.

The **second** path to Sustainable Development is called Smart Growth. They put a line around the city and tell you no growth can take place outside that line. Urban sprawl, they say disdainfully.

They refuse to build more roads as a ploy to get you out of your car into public transportation, restricting mobility. New highways, they say are feeders to more development. In many smart growth cities new apartment buildings now have no garages or parking lots – we don't want any stinking cars!

Smart Growth creates an unnatural restriction on space inside the controlled city limits—so there is a shortage of houses, and prices go up. That means populations will have to be controlled, because now there is a shortage of land.

Smart Growth advocates force individuals to live in denser communities that take up smaller tracts of land per housing unit. Planning advocates and government bureaucrats are forcing such planned communities across the state and nation, and those plans put severe controls on water, energy and private property. In fact, there can be no private property in a smart growth community.

The **Third** way to Sustainable Development--inside the human habitat areas, (our cities and towns) government is steadily being controlled by an elite ruling class called stakeholder Councils. These are mostly Non-governmental organizations, or NGOs, who, like thieves in the night, just show up to stake their claim to enforce their own private agendas.

The function of legitimate elected government within the Sustainablism system is fast becoming little more than the rubber stamp to create and enforce the dictates of the councils. Once the councils are established, it becomes nearly impossible to discuss issues with your elected representatives. Instead they will automatically refer you to the proper council or administration or department, run by unresponsive appointed hacks armed with their own political agenda.

Consequently, they control almost all business decisions. They can dictate the kind of building materials you may use in your home – or whether you can build on your property at all. They decide if roads are built. How much water can be used. How downtowns will look through

Continues on Page 11

Continued from Page 10 - Agenda 21 and the destruction of American liberty

historic preservation. How neighborhoods will be built.

These non-elected councils fit almost perfectly the definition of a State Soviet: a system of councils that report to an apex council and then implement a predetermined outcome. Soviets are the operating mechanism of a government-controlled economy – the exact opposite of a Constitutional Republic.

The **fourth** path to Sustainable Development, are Public/Private Partnerships as mentioned before. You hear the propaganda of the PPPs nightly on your television as their commercials tell you to go green.

And they use Congress to build more wealth and power. GE used their partnership with government to ban their own product – the incandescent light bulb and replace it with the new “green” bulbs. By next year you won’t be allowed to buy incandescent bulbs. Why? Because GE can make three times as much from the new ones as they are more expensive.

Such is the reality of green industry. In fact, there would be no green industry if not for the billions of dollars in grant money shelled out to the partnerships to develop alternative energy schemes.

ICLEI

Many Americans ask how dangerous international policies can suddenly turn up in local government, all seemingly uniform to those in communities across the nation and around the globe. The answer – Meet ICLEI, a non-profit, private foundation, dedicated to enforcing Agenda 21 in every community.

Originally known as the International Council for Local Environmental Initiatives (ICLEI), today the group simply calls itself “ICLEI – Local Governments for Sustainability.” In 1992, ICLEI was one of the groups instrumental in creating Agenda 21. ICLEI is now operating in more than 600 cities in all 50 states. The group is shooting for 1,000 member cities in the next three years.

Here are just some of the programs ICLEI provides cities and towns, in order to spread their own particular political agenda in the name of “community services” and environmental protection:

Software products and associated training, Access to a network of experts, newsletters, conferences and training workshops, Toolkits, online resources, case studies, fact sheets, policy and practice manuals. And, then there’s **Notification of relevant grant opportunities** – this is the important one – money – with severe strings attached.

Around the nation, ICLEI partners with other, established organizations, like the American Planning Association and the International City/County Management Association (ICMA). And then there is the Renaissance Planning Group.

These groups, and hundreds more like them, work hand in hand with groups like U.S. Conference of Mayors, the National Governors Association, the National League of Cities, the National Association of County Administrators and more that your elected representatives be-

long to. That’s how these policies quickly spread across the nation as enforced regulations.

As a result, one of the most popular tools now to control energy use is the energy audit and building review. They establish quotas for electrical use, and for heating and cooling pumps, and water use. Weatherization of existing buildings; replacing incandescent light bulbs; and on and on. That means government bureaucrats will come into your home or office building and determine the amount of potential energy use you should have.

You will be given a list of “recommendations” necessary to bring your home into compliance. These may include the need for a new roof; new energy efficient appliances; new windows, etc.

In Oakland California, the city council did just these things, and the result was an average cost to every homeowner of at least \$35,000. Those who don’t comply will be fined, and possibly unable to sell their home until they do.

Across the nation, power companies, in partnership with government planners, are forcing the use of Smart Meters. These meters contain RFID chips. The technology enables the power company to keep track of how much power you are using and control, regulate and ration your use. They will set the temperature in your home. If they decide that you are using too much hot water for your showers or washing machines, or too much air conditioning, your electricity will automatically be turned down or even off. Moreover, a future goal is to have all appliances replaced with those containing that same RFID chip, which the smart meter will “speak to” for more regulations and controls.

There are policies being advocated to place taxes on use of toilet paper; on the number of miles you drive; and on the use of plastic bags.

The EPA is now providing funding to NGO groups to run training programs for people to photograph and report neighbors who may be “committing crimes against the environment.”

Welcome to the utopia of Sustainable Development. 🌱

[Tom DeWeese](#) is president of the American Policy Center and one of the leading experts on Agenda 21. He writes a monthly newsletter, *The DeWeese Report*, available at www.deweese-report.com, and is author of the new book, *“Now Tell Me I Was Wrong.”* available on Amazon.com.

[Make a Comment](#) • [Email Link](#)
[Send Letter to Editor](#) • [Save Link](#)

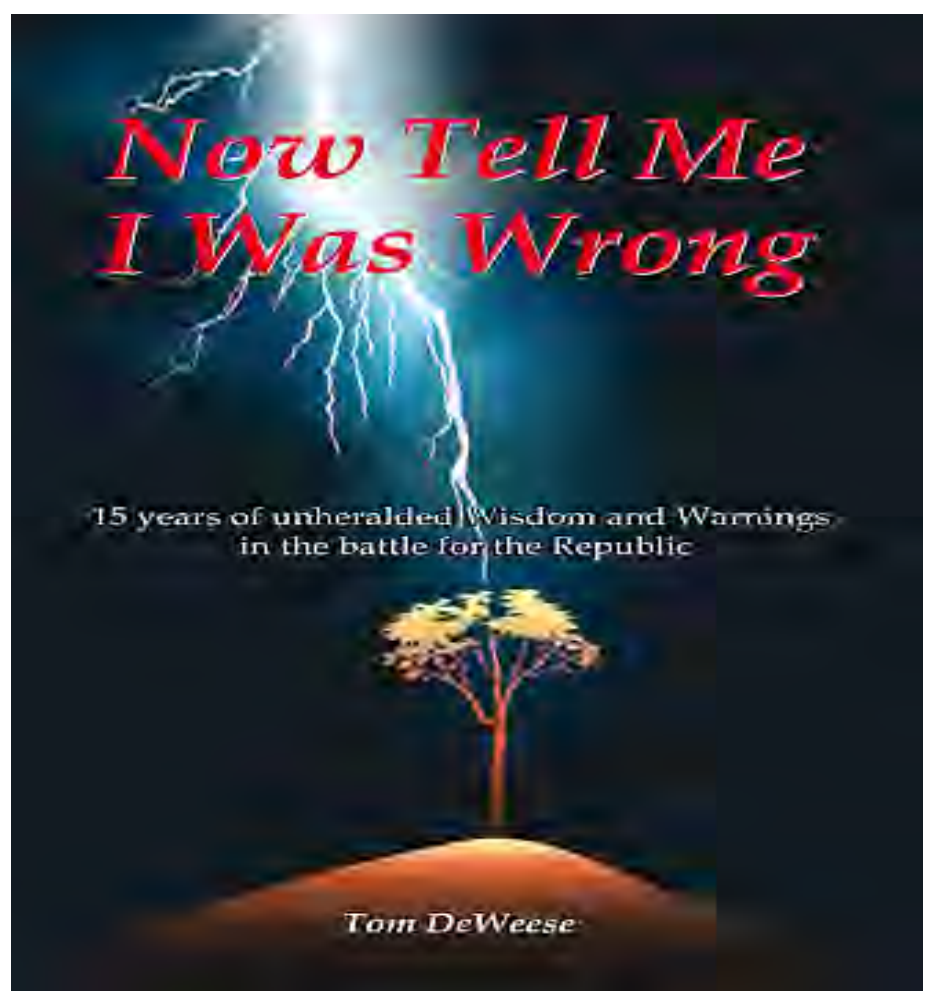

WHAT IS UNITED NATIONS AGENDA 21?

By Rosa Koire

[Make a Comment](#) • [Email Link](#) • [Send Letter to Editor](#) • [Save Link](#)



CONSIDERING that its policies are woven into all the General Plans of the cities and counties, it's important for people to know where these policies are coming from. While many people support the United Nations for its peace-making efforts, few know that they have very specific land use policies that they expect to see implemented in every city, county, state and nation. The specific plan is called United Nations Agenda 21 Sustainable Development, which has its basis in [Communitarianism](#). By now, most Americans have heard of sustainable development but are largely unaware of Agenda 21.

In a nutshell, the plan calls for governments to take control of all land use and not leave any of the decision making in the hands of private property owners. It is assumed that people are not good stewards of their land and the government will do a better job if they are in control. Individual rights in general are to give way to the needs of communities as determined by the governing body. Moreover, people should be rounded up off the land and packed into human settlements, or islands of human habitation, close to employment centers and transportation. Another program, called the Wildlands Project spells out how most of the land is to be set aside for non-humans.

Agenda 21 cites the affluence of Americans as being a major problem which needs to be corrected. It calls for lowering the standard of living for Americans so that the people in poorer countries will have more, a redistribution of wealth. Although people around the world aspire to achieve the levels of prosperity we have in our country, and will risk their lives to get here, Americans are cast in a very negative light and need to be taken down to a condition closer to average in the world. Only then, they say, will there be social justice which is a cornerstone of the U.N. Agenda 21 plan.

Agenda 21 policies date back to the 1970's but it

got its real start in 1992 at the Earth Summit in Rio de Janeiro when President Bush signed onto it. President Clinton signed it later and continued the program in the United States. Agenda 21 is 'soft-law' and did not have to be voted on by the Congress. A non-governmental organization called the International Council of Local Environmental Initiatives, ICLEI, is tasked with carrying out the goals of Agenda 21. Over 600 cities in the U.S. are members, and that number is growing. The costs are paid by taxpayers.

It's time that people educate themselves and read the document and related commentary. After that, get a copy of your city or county's General Plan and read it. You will find all sorts of policies that are nearly identical to those in U.N. Agenda 21. Unfortunately, their policies have advanced largely unnoticed and we are now in the end game. People need to identify their elected officials who are promoting the U.N.'s policies and hold them accountable for their actions. Only when we've identified who the people are and what they are trying to do will we be able to evaluate whether or not we approve of the policies they are putting forward. Some people may think it's appropriate for agencies outside the United States to set our policies and some people will not. The question is, aren't Americans able to develop their own policies? Should we rely on an organization that consists of member nations that have different forms of governments, most of which do not value individual rights as much as we do? It's time to bring U.N. Agenda 21 out in the open where we can have these debates and then set our own policies in accordance with our Constitution and Bill of Rights.

Ok, you say, interesting, but I don't see how that really affects me. Here are a few ways:

No matter where you live, I'll bet that there have been hundreds of condos built in the center of your town recently. Over the last ten years there has been a 'planning revolution' across the US. Your commercial, industrial, and multi-residential land was rezoned to 'mixed use.' Nearly

Continues on Page 13

Continued from Page 12 - WHAT IS UNITED NATIONS AGENDA 21?

everything that got approvals for development was designed the same way: ground floor retail with two stories of residential above. Mixed use. Very hard to finance for construction, and very hard to manage since it has to have a high density of people in order to justify the retail. A lot of it is empty and most of the ground floor retail is empty too. High bankruptcy rate.

So what? Most of your towns provided funding and/or infrastructure development for these private projects. They used Redevelopment Agency funds. Your money. Specifically, your property taxes. Notice how there's very little money in your General Funds now, and most of that is going to pay Police and Fire? Your street lights are off, your parks are shaggy, your roads are pot-holed, your hospitals are closing. The money that should be used for these things is diverted into the Redevelopment Agency. It's the only agency in government that can float a bond without a vote of the people. And they did that, and now you're paying off those bonds for the next 45 years with your property taxes. Did you know that?

So, what does this have to do with Agenda 21?

Redevelopment is a tool used to further the Agenda 21 vision of remaking America's cities. With redevelopment, cities have the right to take property by eminent domain---against the will of the property owner, and give it or sell it to a private developer. By declaring an area of town 'blighted' (and in some cities over 90% of the city area has been declared blighted) the property taxes in that area can be diverted away from the General Fund. This constriction of available funds is impoverishing the cities, forcing them to offer less and less services, and reducing your standard of living. They'll be telling you that it's better, however, since they've put in nice street lights and colored paving. The money gets re-directed into the Redevelopment Agency and handed out to favored developers building low income housing and mixed use. Smart Growth. Cities have had thousands of condos built in the redevelopment areas and are telling you that you are terrible for wanting your own yard, for wanting privacy, for not wanting to be dictated to by a Condo Homeowner's Association Board, for being anti-social, for not going along to get along, for not moving into a cramped apartment downtown where they can use your property taxes for paying off that huge bond debt. But it's not working, and you don't want to move in there. So they have to make you. Read on.

Human habitation, as it is referred to now, is restricted to lands within the Urban Growth Boundaries of the city. Only certain building designs are permitted. Rural property is more and more restricted in what uses can be on it. Although counties say that they support agricultural uses, eating locally produced food, farmer's markets, etc, in fact there are so many regulations restricting water and land use (there are scenic corridors, inland rural corridors, baylands corridors,

area plans, specific plans, redevelopment plans, huge fees, fines) that farmers are losing their lands altogether. County roads are not being paved. The push is for people to get off of the land, become more dependent, come into the cities. To get out of the suburbs and into the cities. Out of their private homes and into condos. Out of their private cars and onto their bikes.

Bikes. What does that have to do with it? I like to ride my bike and so do you. So what? Bicycle advocacy groups are very powerful now. Advocacy. A fancy word for lobbying, influencing, and maybe strong-arming the public and politicians. What's the connection with bike groups? National groups such as Complete Streets, Thunderhead Alliance, and others, have training programs teaching their members how to pressure for redevelopment, and training candidates for office. It's not just about bike lanes, it's about remaking cities and rural areas to the 'sustainable model'. High density urban development without parking for cars is the goal. This means that whole towns need to be demolished and rebuilt in the image of sustainable development. Bike groups are being used as the 'shock troops' for this plan.

What plan? We're losing our homes since this recession/depression began, and many of us could never afford those homes to begin with. We got cheap money, used whatever we had to squeak into those homes, and now some of us lost them. We were lured, indebted, and sunk. Whole neighborhoods are empty in some places. Some are being bulldozed. Cities cannot afford to extend services outside of their core areas. Slowly, people will not be able to afford single family homes. Will not be able to afford private cars. Will be more dependent. More restricted. More easily watched and monitored.

This plan is a whole life plan. It involves the educational system, the energy market, the transportation system, the governmental system, the health care system, food production, and more. The plan is to restrict your choices, limit your funds, narrow your freedoms, and take away your voice. One of the ways is by using the Delphi Technique to 'manufacture consensus.' Another is to infiltrate community groups or actually start neighborhood associations with hand-picked 'leaders'. Another is to groom and train future candidates for local offices. Another is to sponsor non-governmental groups that go into schools and train children. Another is to offer federal and private grants and funding for city programs that further the agenda. Another is to educate a new generation of land use planners to require New Urbanism. Another is to convert factories to other uses, introduce energy measures that penalize manufacturing, and set energy consumption goals to pre-1985 levels. Another is to allow unregulated immigration in order to lower standards of living and drain local resources.

[The Post Sustainability Institute](#) 

[Make a Comment](#) • [Email Link](#)
[Send Letter to Editor](#) • [Save Link](#)



General Considerations in Fruit, Nut and Vegetable Production (Part 1) By Powell Gammill

[Make a Comment](#) • [Email Link](#) • [Send Letter to Editor](#) • [Save Link](#)



HOW do you grow enough food to support yourself, your family and maybe barter excess?

Unless you own land you likely don't. That doesn't mean you can't supplement your food sources.

But unless you have a reasonable amount of land and a proper place to store food to get you through the non-growing winter season, then growing your own food is only a supplement and *for right now* with relatively low grocery prices not a cost effective one either. But growing food is a good skill to learn right now, because it both is and it is not as easy as putting seeds in the ground. And you do not want to be learning how to grow food when you have no other choice but to grow your own, because you will make serious errors that will result in food loss and plant loss.

There is also sharecropping: Finding unused land and persuading the owner to let you farm it for a share of the produce. But without a contract, the land owner can come and retake possession of the property and it's contents at will.

Indoor container gardening will be covered by Barbara Peterson. Some of what I will say will be applicable to indoor or apartment balcony gardening. But containers can also be important outdoors in areas usually near the home where a slab of concrete has replaced soil. Indoors or outdoors, watering usually has to occur twice as often as outdoors due to a smaller container soil volume size. Outdoor containers also can suffer heat/cold swings at a much greater rate. Of course a raised bed garden is a container garden of sorts and indeed can be a genuine container.

I am a lazy farmer. I want the plants to take care of themselves and provide me with food. So this month I will discuss perennials---plants that produce food for many years as opposed to annuals that (usually) must be reseeded each year. If I need vegetation for other reasons: for example shade, wind screen, privacy, crime control, beauty, aviary or apiary, I want it to produce food too. In fact, I want it to have many uses and that takes forethought and planning ahead of time. But the bottom line: If it doesn't produce food I am not interested.

The southwestern desert of Phoenix, Arizona is my specialty which is unusual in that most gardening/urban farming books and Internet meanderings are rather focused on wetter and colder areas. Since this is a national publication, I will attempt to comment on all conditions that are applicable in the world, but an **critical** part of farming is to know **your** own climate, seasons, soil, rain patterns, humidity, and prevailing wind patterns. Learn them **now** before you start planting.

There are many first things to do.

Observation is one of them.

It is important to observe the area you plan to urban farm, homestead farm, garden and/or container garden. How big of an area are you looking to plant? Look at the adjacent properties. What are the resources? What are the dimensions? What are the differences? What naturally grows in the area? This will help tell you what might grow in the area that is not natural to the area and what might not. What have others had success growing?

What utility lines are overhead (location and height)? What utility pipes are underground (location and depth)? Most cities provide a free service that will come out and mark underground utilities with a phone call. This does of course alert snoopy government officials that you plan on doing digging...but.... Generally they mark on an easement and not the actual path the lines take onto your property. You are civilly and criminally responsible for damage to those lines. Fines and lawsuits from neighboring businesses whose income is affected by an outage can be very expensive. Breaching a gas or electric line can be deadly.

Sketch out the area (to scale). Mark it North, South, East, West. Place buildings, current objects, resources located both within the property and outside its edges. Fencing can act as wind brakes, heat storage and trellises in addition to keeping some animals and trespassers out. Indicate the directions of prevailing winds, any street noise or noisy neighbors, street water direction as it passes by, runoff directions, overhead lines, underground pipes, shade patterns. Indicate location of the rising and setting sun on June 21st and Dec. 21st (and the direction of the shadows cast). Indeed if you really want a good indication, plot the solar path across the sky on those two days to give you an idea of both direction of sunlight and shadow (the opposite angle direction) every hour of the day.

Planning

From here you can decide if any objects need to be removed or moved to implement your overall strategy.



From here you can plan where to plant everything. In my opinion, things that need the most attention and constant harvesting like gardens of annuals or fresh herbs should be nearest the home... because they need the most attention and you want to only have to step out of the house if you need to pluck something for the next meal. Trees and shrubs get planted farther out, unless shrubs are used near the home for shade, privacy and acoustic dampening (in addition to food) or the trees are *espaliered*.

Remember plants against the home may be protected from winds and frost (heat loss from home). But in the northern hemisphere the north side of a home is usually in partial to constant shade.

And what to plant and when and why will be discussed in a future series of articles covering edible trees, shrubs, vines, perennial and annual vegetables, herbs, fruits and nuts.

Continues on Page 15

Continued from Page 15 - General Considerations in Fruit, Nut and Vegetable Production (Part 1)

[Create a wind rose pattern plot](#) (USA)

Average temps

Temperature is very important to plants. The two most important temperature points are 86 degrees Fahrenheit (30°C), above which the plant's growth and production starts to slow down---do you like to work when its hot? Above this temp and the plant's transpiration (equivalent of sweating) starts to shut down to conserve water.

The other important temperature is 32 degrees Fahrenheit (0°C): Freezing can kill or damage a plant. Some plants go dormant (shed leaves) or naturally die off (annuals) before this. Others need protection to survive or later come out of dormancy uninjured---usually non-native perennials. And if fruit is present (ex: citrus) it may need protection. Protection is usually provided by cloth covering and heavy watering. Placing stones around the tree can also help. Generally the trees at the periphery of an orchard are most at risk. Obviously the weight of snow and ice can break limbs. Dormancy is usually the best time to prune plants.

[Global temperature Temps and precipitation](#)

Water

Where is the water coming from? Municipal source, river, wells, rain, air conditioning runoff?---some people even collect their refrigerator condensation. [Greywater](#): water reuse from laundry machines, showers, bathtubs, sinks and even dishwashers and kitchen sinks. Generally greywater is not used on annuals (i.e., the garden) but instead used to water trees or create a wetland reclamation area next to a pond. Where does the water go? **Where does the water need to go?** Is the water chlorinated (inexpensive in line activated charcoal filters can remove it)? What is the water's mineral content (The EPA requires commercial/municipal providers to provide the results for their source.)? Will your water source build up salts in your soil? Is there too much water? Too little? Ignorant neighbors may be eager to dump the rain water that comes onto their land onto yours if you need it and ask.

How to direct the water to where you want it to go? The proper draining of water? Observation can usually point to where runoff occurs by looking for erosion, silt deposits and floating organic debris accumulating. Low spots are where water accumulates after a rain. If the water is not draining into the ground within a few hours this is a problem area. If you are planting here you may need to build up the area to let it drain properly. If water is precious, terracing, swales (shallow ditches around tree lines) and berming up these areas will allow water to stay on the property by slowing down its exit and giving it time to soak into the ground.

Generally there are low areas and high areas of your property. You can measure the surface contours using a [homemade A-frame and bunyip](#).

An A-frame is a frame constructed of three pieces of wood to form a structure resembling the capital letter A. In this case with a pendulum suspended from the top point and a mark is made on the cross member where the two sides placed against the ground are level as measured and marked on level ground. When placed against the ground the pendulum swings toward the mark. The A-frame is used to find points across a slope that are at exactly the same level. These points are on a line that is the same level across the slope and are designated a contour

line. Barriers made *along a contour* will stop or slow the flow of water most efficiently.

A bunyip is two yard sticks (homemade 2 x 2's with markings work) and an attached 25 foot long length of translucent/transparent plastic (Tygon) tubing filled with water. One person holds while another moves around measuring in inches the water drop or rise between the two points as reported by the bunyip difference in the two measuring sticks. With a little patience the entire contours of the yard can be mapped out. Every three inches equals approx. one degree of slope. Generally you want between a one to two degree slope to encourage water movement without heavy erosion.

Measure how much rain water falls on your property and roof top (if you intend to catch and divert the roof runoff) in a year on average, and at likely peaks. Avg. rainfall (in inches) x 0.57 gallons/sq. ft./inch of rain x sq. ft of surface being calculated.

For 1/3 of an acre for example equals approx. 15,000 sq. ft. of area. Multiply by 0.57 gallons/sq. ft. equals 8,550 gallons per inch of rainfall on that property annually. So here one needs to find out the average rainfall for an area and ideally the historical monthly distributions (rain patterns) for both the monthly average and worst case scenario. This can determine the heaviest loads likely to be faced by any property and whether the earthworks will handle the rainfall.

[Get your monthly average rainfall](#) (USA)

Roofs are easy to calculate. Ignore the pitch. All you have to do is measure the outside dimensions. This will give you the area. You can calculate the rest from above. Whether you capture this runoff into cisterns or plant it directly into the ground, rainwater is the cleanest of water sources. It is pure water. But it will wash any dust, bird excrement and plant material on the roof with it along with any degraded material the roof is made out of. The best water for all plants including your gardens.

Fresh water is precious in ever increasing areas. [Conserving water](#) is an economical solution. This can be done through planing water thrifty crops (no fun at all), enriching the ground's ability to store water (water banking), decreasing ground (and plant) evaporation rates through planting vegetation and mulching, and putting water only where it is needed and in the correct amounts at a time when the plants in that area can most utilize it.

Drip irrigation is one such method. It lends itself to automated watering and is sophisticated enough that it can be connected to rain gauges and a humidity measurer so it won't turn on unless needed. Additionally wind gauges can delay watering so spray/evaporation losses are minimized. And even soil moisture sensors can decide whether or not it is time to water. These automated systems can cost a lot. Even drip irrigation systems without this complexity (i.e., manual) can cost a lot as the systems are designed to only last a year before the plastic needs replacement. And in my experience a balance system unless it is near its water source (due to frictional losses in a long water line) is limited to around 20 emitters per line.

Ideally watering should be done as a heavy irrigation delivered to where the roots are, and then several days to weeks depending upon conditions for drying to occur. This is a general rule and certain plants may require more water and

Continues on Page 17

Continued from Page 16 - General Considerations in Fruit, Nut and Vegetable Production (Part 1)

others much less. Annuals are frequently watered daily.

Soil

What type of soil do you have? Does it drain well? Does it hold water? Is it fertile?

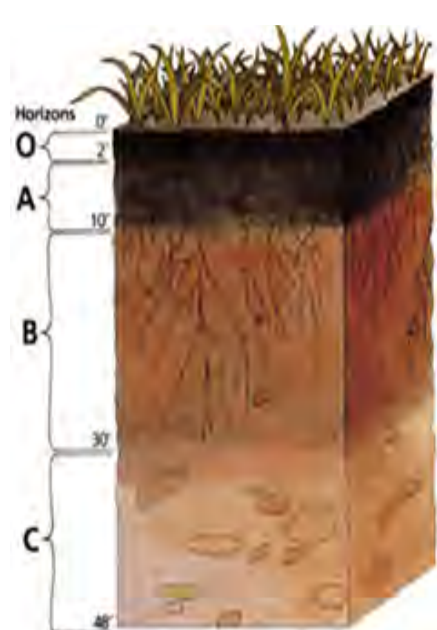

Soil is rock that has broken down. It weathered from rocks, finally forming sand and eventually fine particles of silt and clay. Minerals are released in the process. Organic material from dead or discarded plant material, and deceased soil organisms

decomposes into future plant food or water holding material called humus.

Soil will have a color. Generally the blacker (darker due to organic material present) it is the better. If you dig down a couple of feet in your property you should find an upper soil layer usually some four to eight inches, followed by one or more layers below. The upper layer is the top soil. This is where the majority of roots for any plant will be found. This is where organic material is breaking down. This is where the majority of microbial life is. If you are really lucky it is deeper than eight inches. If you are really unlucky it is barely present. If it is barely present you will have to make your top soil using a method called [sheet layered](#) or lasagna composting, where layers of compost and newspaper are placed atop a cardboard weed barrier and then planted with the idea that this layer will breakdown into a rich soil within the year. Unless you have a ready source of compost this is expensive.

Any white layer is usually salt buildup from repeated too light an irrigation with improper drainage depositing the minerals contained in the water. It should taste salty.

You want to know the breakdown of soil texture into percentages of sandy, loamy (silt) and clay. The sandier the soil the quicker water penetrates and drains away. The clayier the soil water tends to run off and not penetrate the surface. Loamy soil tends to soak up large volume of water per its weight due to its high organic/humus content. Humus is what remains of broken down (decayed) vegetable matter. Some areas of soil can be adjusted with sand or compost (humus) to increase certain attributes. But large scales at a time are labor intensive and destructive to soil life with one exception: Lasagna composting.

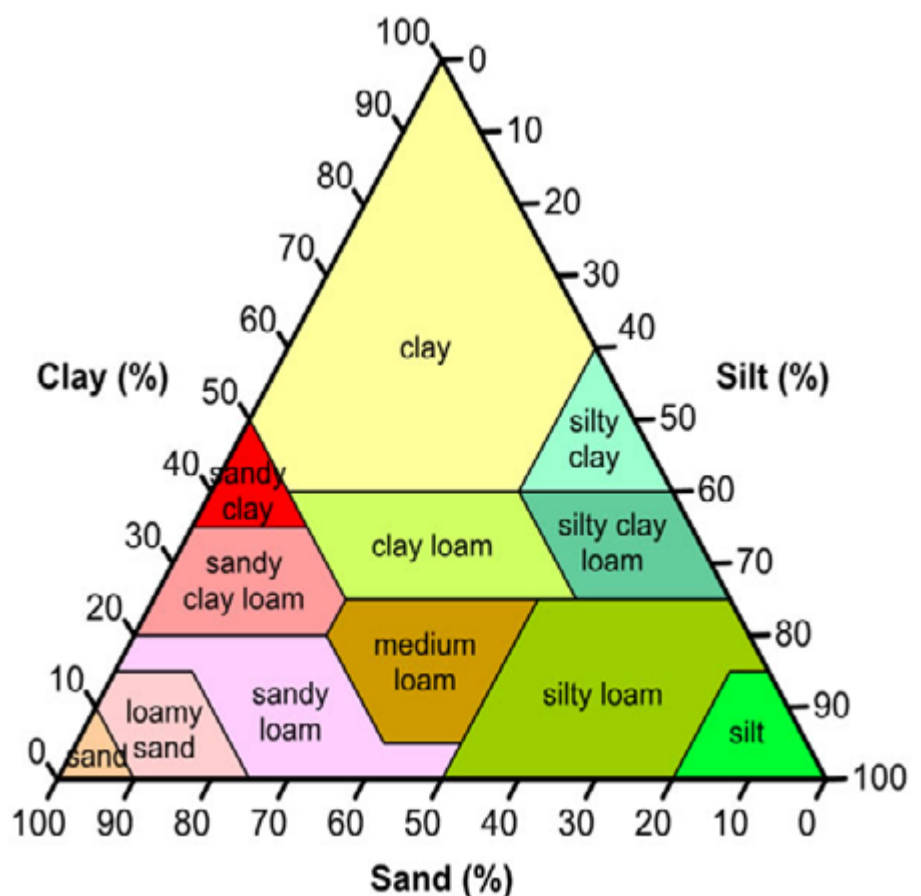

Some plants prefer rapidly draining soils and mixing sand into a composted top soil can promote this.

Soil tests

Clump test

Take a handful and squeeze it. Open up your

hand. Sandy soil will fall apart. High percentage clay or silt will hold together. Touching the clump will either break it apart (= silt/loamy) or deform and remain a bound clump (= clay). While in your hands rub it with your fingers... what characteristics does it feel like. Smell? Some people will taste it, but since I don't expect you to taste many soils I see little point in developing a palate for how prevalent minerals found is soil taste.

Ratio of clay, loamy and sand

Take a roughly cylindrical glass jar (ex: Mason). Take a garden scoop full of soil and place in the jar. Fill about 4/5th the way with water, distilled water which can be purchased at a grocery store is best. Shake really well. Measure pH (next test below) if desired. Then add a couple of drops of dish detergent which will help speed up clay settling. Shake jar well, then set down. At one minute mark settled material level this will be the sand. As one hour mark the next settled level; this will be the loamy material. At 24 hours mark the last settled level; this will be the clay. Measure the distances between each and divide by the total height and this will give you the percentages of each material (see soil chart above).

Soil pH is usually **the most important** consideration. pH is a measure of soil acidity or the opposite, alkalinity. pH is measured on a scale of zero to 14, with zero being most acidic and 14 being most alkaline. A pH of 7 is neutral. This is also logarithmic scale, meaning as you go from one whole number to the next it is ten times more or less acidic/alkaline.

Most soil in the USA is acidic. This is due to it being formed in good to heavy rainfall which removes certain buffering compounds and leave behind acidic components. Often too acidic. In the southwest it tends to be alkaline, due to the lack of rainfall. Alkaline is very bad. Plants cannot take up (minerals) critical nutrients well (ex.: phosphorus) above a pH of 6.8 (slightly acidic), and not at all above a pH of 8 which means no plant growth. Below a pH of around 5.5 most things can't grow (but, for example, blueberries love a pH down to 4.5 and this can be used to help out compete other plants). Below a pH of 4.5 few things grow. The ideal pH of most growing things is between 6.2 and 6.8. Learn what the ideal pH is of the things you plant.

Nutrient Availability Chart

Nutrient	Soil pH									
	4.5	5.0	5.5	6.0	6.5	7.0	7.5	8.0	8.5	9.0
Nitrogen	SA	MA	MA	HA	HA	HA	HA	MA	MA	SA
Phosphorus	SA	SA	MA	HA	HA	HA	MA	MA	SA	MA
Potassium	SA	MA	MA	HA	HA	HA	HA	MA	MA	MA
Sulfur	SA	MA	MA	HA	HA	HA	HA	MA	MA	MA
Calcium	SA	SA	MA	MA	MA	HA	HA	MA	MA	MA
Magnesium	SA	SA	MA	MA	MA	HA	HA	MA	MA	MA
Iron	SA	SA	MA	MA	MA	HA	HA	MA	MA	MA
Manganese	SA	SA	MA	MA	MA	HA	HA	MA	MA	MA
Boron	SA	SA	MA	MA	MA	HA	HA	MA	MA	MA
Copper	SA	SA	MA	MA	MA	HA	HA	MA	MA	MA
Zinc	SA	SA	MA	MA	MA	HA	HA	MA	MA	MA
Molybdenum	SA	SA	MA	MA	MA	HA	HA	MA	MA	MA

Acidic | Optimum pH Zone for Soil

Key:
 SA = Very Acidic
 MA = Moderately Acidic
 HA = Moderately Alkaline

The most convenient way of [testing pH is with pH testing strips](#). It can be very accurate. It does not require faithful cleaning the way a testing meter does. Select the strips that cover the desired range with a little cushion on either side; which should be pH 3.5 - pH 9. Put some soil in a clean container, preferably prewashed with distilled water to remove any dishwasher detergent that may remain. Add distilled water (available from your grocer). Shake, settle and test by dipping in the upper soil-water and following the incubation times on the test strip instructions. Then compare colors on strip to pH

Continues on Page 18

Continued from Page 17 - General Considerations in Fruit, Nut and Vegetable Production (Part 1)

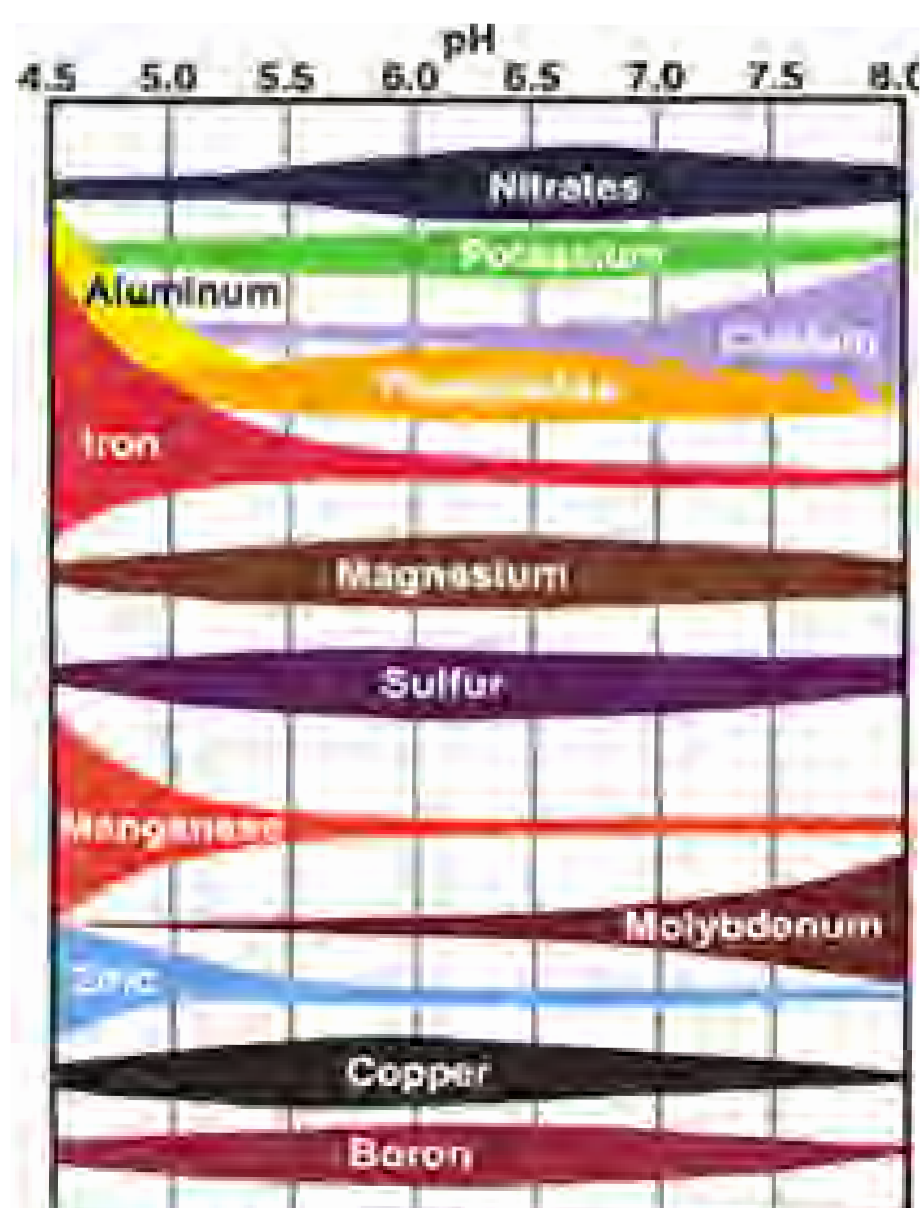

color evaluation chart provided by the test strip manufacturer.

[pH can be adjusted](#) up (made less acidic) using lime or gypsum. pH can be adjusted down (made less alkaline) with elemental sulfur or pine needles. This takes time and multiple applications over many months. pH should thereafter be tested every fall before planting. Test strips have a long shelf life in non-humid environments as long as the test strip package is kept in the dark (I like to wrap them in aluminum foil between uses).

Percolation test (How fast does your soil drain?) Dig a hole one foot deep and in diameter. Fill the hole with water. Let it completely drain. Then immediately fill it again. Measure drainage in inches over time: Most conveniently by leaving a ruler in the hole. If it completely drains in more than 45 minutes, but under two hours great. Up to four hours is fine.

More than four hours is a big problem. Water will tend to hang around the roots literally drowning the plant--there is a lot of air in the soil and roots actually breath--and promoting rot. Add sand.

Less than 45 minutes is also a big problem as the water is draining away before the plant can consume much of it which is wasting water and stressing the plant. Add clay and loamy soil.

You can get your soil professionally tested at a soil lab for around \$50. This should include micro-nutrient levels. Follow their sampling and shipping instructions. Avoid metal in sampling as much as possible as it can contaminate the samples. Generally you gather many small samples and mix them into one or the testing lab will mix them for you if separate cores are shipped in a single container. [One good test lab: [Midwest Labs](#); I recommend "S3C with recommendations" for \$26.50.] Your [Cooperative Extension Service](#) will have a list of local testing labs.

Nitrogen is associated with lush vegetative growth, adequate phosphorus is required for flowering and fruiting, and potassium is necessary for durability and disease resistance. This is the so called NPK standing for the atomic symbols of these three elements. You will see fertilizer with for example these notations: 5-3-3 or 30-20-30. Meaning 5 parts nitrogen (N) to 3 parts phosphorus (P) to three parts potassium (K) or 30 parts nitrogen to 20 parts phosphorus to 30 parts potassium respectively. Whenever you see high numbers like 30-20-30 you know it is synthetic fertilize. Low numbers like 5-3-3

indicate an organic source which to me is preferable as you will not burn the roots. Calcium, sulfur, and magnesium are also required in comparatively large quantities. These six nutrients are referred to as macro-nutrients.

Micro-nutrients, are required in very small amounts. These include such elements as copper, zinc, iron, and boron. Other mineral nutrients at low concentrations considered essential to growth of some plants are Ni and Co. Still other specific plants may require other minerals present for growth and fruiting.

A good soil electrical conductivity (EC) level tested with an EC meter will be somewhere between 200 $\mu\text{S}/\text{cm}$ and 1200 $\mu\text{S}/\text{cm}$ (1.2 MS/cm). Any soils below 200 $\mu\text{S}/\text{cm}$ means there is not enough nutrients available to the plant and could perhaps show a sterile soil with little microbial activity. An EC above 1200 $\mu\text{S}/\text{cm}$ may indicate too much salt, too high a fertilizer concentration or perhaps a salinity problem from lack of drainage so keep your EC within the above range.

Microbial soil life is also extremely important. Microbial life is beneficial. It provides nutrients to the plants. It recycles nitrogen the soil. It repels or kills plant predators. Rehabilitating soil, increasing life, increasing humus though sheet mulching.

Do not underestimate the importance of your soil's life. The quintessential Urban Farmer in Phoenix, Greg Peterson, tried a method of killing Burmuda grass by covering the area with black plastic and letting the sun do the rest. Worked like a charm. Not a single Burmuda seed survived--an amazing achievement! Unfortunately it killed everything else as well. He has been unable to grow a decent garden there for many years despite attempts at recovering the soil. Now he ripped it out and replaced the soil.

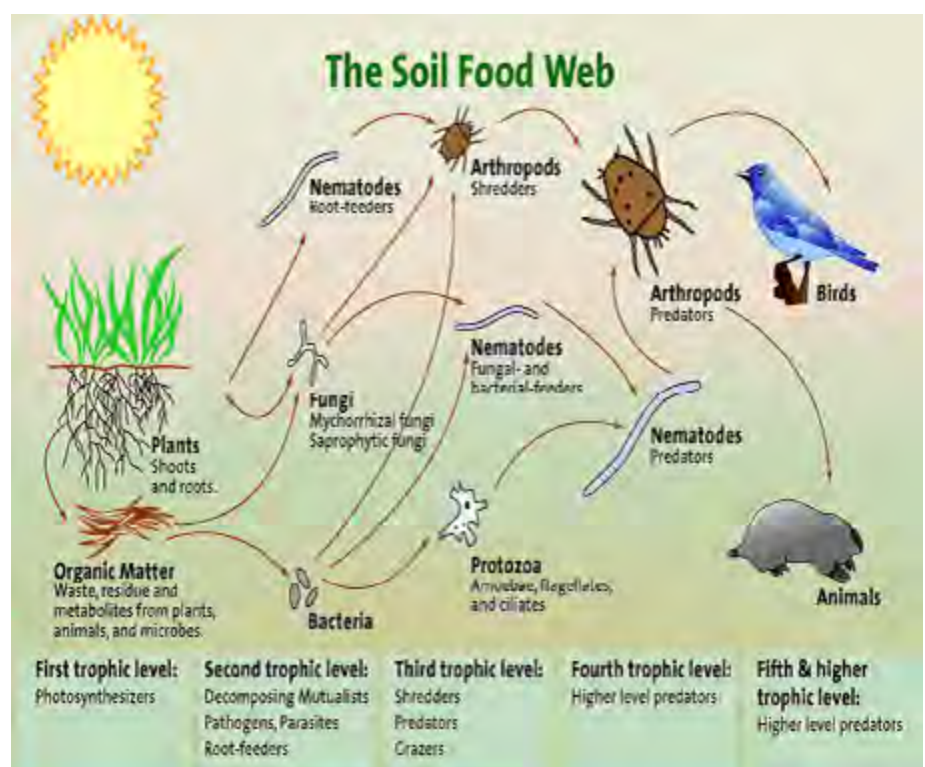

Disturbing soil. Macroscopic soil life: Earthworms; 25 or more per sq. foot is considered good. But you won't find that concentration in a desert. Other critters inhabit the soil as well. Often they help turn the soil over by burrowing through it or carving up chunks of organic detritus and excreting pieces more readily handled by soil microorganisms. Disturbing the soil should be avoided **period**. It is extremely disruptive to soil organisms and can take more than a year (sometimes years!) to recover resulting in poor plant performance. The rule is, if you have to disrupt the soil such as tilling, do it only once. Do whatever amending you are going to do quickly to minimize sun exposure and desiccation and replace and possibly water.

Compost

This is an overview and a brief one at that. There are books just on composting. All vegetable matter can compost. There are four main methods of composting for homeowners: Com-

Continues on Page 19

Continued from Page 18 - General Considerations in Fruit, Nut and Vegetable Production (Part 1)

posting, Sheet composting, Vermicompost and chickens (with [black soldier fly larvae](#) addendum). Enzymatic breakdown is a commercial form of large scale rapid composting as well. Composting produces methane and other flammable gases. But if done aerobically (with oxygen present), (anaerobically stinks and does not produce quality top soil) you will be left with a high quality pile of dirt in around nine months time if you were occasionally turning the pile and keeping it a little moist. There are commercial composting systems that ostensibly speed the process up as will more frequent turnings. Generally you can do fine on your own without the fancy equipment.

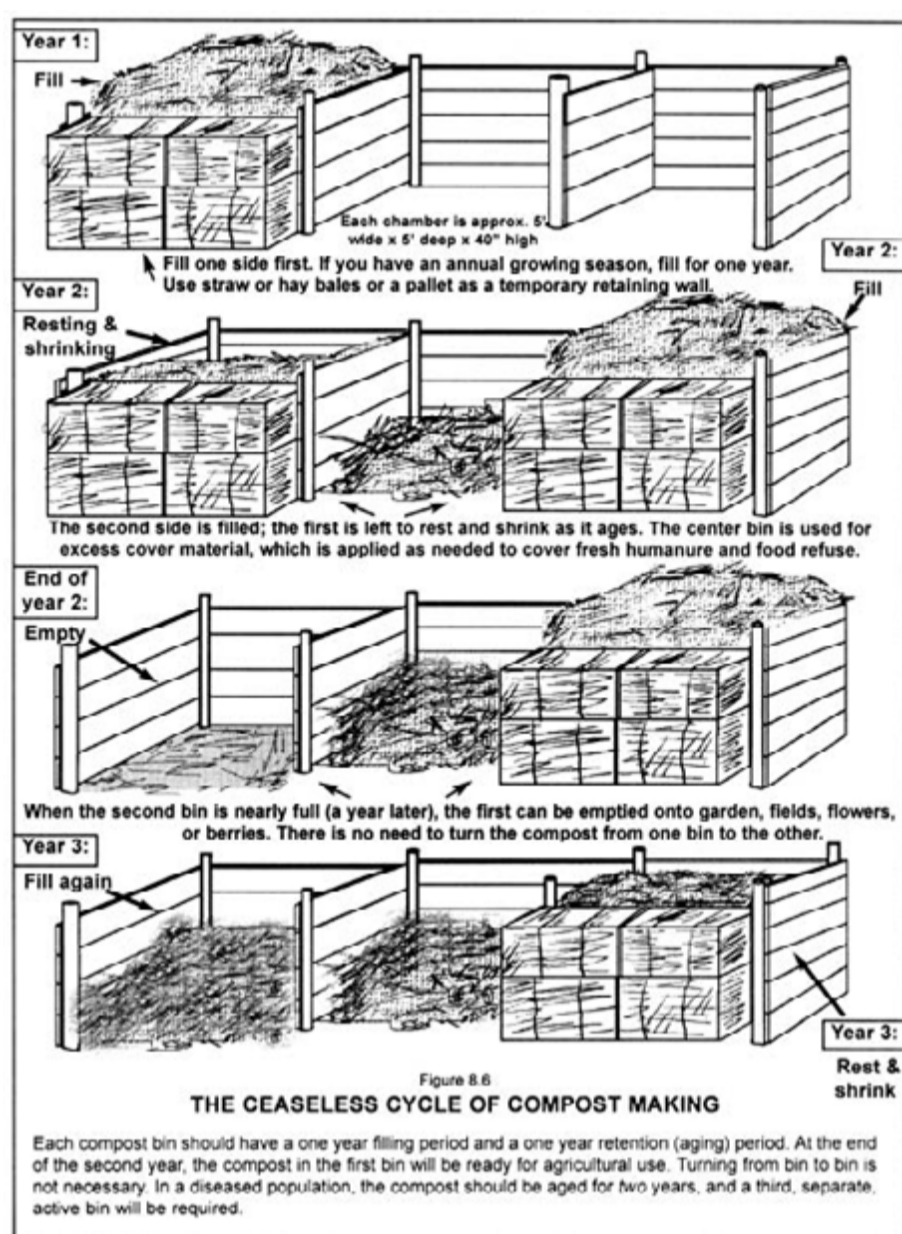

I prefer the three bay approach. One bay for composting materials to dry down in. This material is then broken up into as fine as substance as possible for the composting process to begin. One bay to compost in and the final bay to move the compost pile to when turning. Move back and forth between these two bays. Municipal garbage cans that have been withdrawn to end of life can be used as compost containers with modifications (cities are eager to rid themselves of them). Adding a scoop of fresh compost to the compost pile can help jump start the composting process by bulk adding the active microorganisms. Initially adding earthworms can help as they will migrate down under as the pile heats up. Some water is added. The compost pile will heat up in some cases to 160 degrees Fahrenheit killing off any seeds present. Odors and flies can be a problem. Best to locate away from any houses and local government ordinances may regulate a compost pile. Once the temperature in a compost pile starts to decline the composting process is concluding. This can be measured with a [compost thermometer](#).

Compost material should never contain animal products (there are exceptions and some controversy about this rule, but it is generally accepted). Compost material should consist of "green" material and "brown" material in approx. equal amounts by volume. Green materials provide nitrogen, consisting of moist organic matter such as green grass clippings, discarded kitchen scraps, and weeds (without viable seeds). Brown materials provide carbon, and consist of dead leaves, twigs, sawdust, straw, shredded newspaper (and documents), and other dry organic materials. Actually leaves can be considered either green or brown and so can be used to balance a deficiency in one of the other material on hand.

Compost material can often be gotten for free from a municipality; wood chips from the bulk garbage collection dept. or landscapers. They may even be willing to deliver them to your

house for free, but you don't get to choose the source of the tree. And every week in every city in a certain area people are discarding compost and compostable material in nice black bags ready for you to pickup and use for free---it is called the week for bulk trash pickup and your city has a map of where it is going on. Happy scrounging. Additionally the neighbor's lawn guys may be happy to give you their clippings. Compost is important and only cheap if you make it yourself.

Sheet composting has already been described.

[Vermicompost](#) is the use of **red wiggler worms** in a bucket with a drain (for the so called "worm juice"---**highly** nutrient rich plant food so collect it because in Phoenix it is so dry generally evaporates before it can--sigh--be used). A lid to cut down on odor. Kept under the kitchen sink. Toss any scraps in, including animal products. These red worms will break it down. Start them out with wet newspaper. Add some newspaper every once in a while. In a dry climate like mine you may need to routinely add a little water otherwise in most places pretty maintenance free. The rapidly composted material can be added to the garden.

Chickens. The most amazing creature. Eats all your garbage. Gives you eggs or meat and manure (rapid compost). Feathers. Amusement. Tills your ground. Eats your pests. Just the best and for someone else who raises chickens to write about. The [black soldier fly larvae](#) is the latest variation in composting vegetation producing worm juice and larvae that feed the chickens need for calcium.

Pollination

Will your plant have a healthy sex life?

Generally fruit production happens when the pollen from a male pestle fertilizes a female stamen in a process called fertilization. I know---duh. But different plants have a variety of pollination possibilities. Besides the obvious of the wind or a vector (pollinator like an insect or bat) transferring pollen, many flowers have both male and female parts located inside their flowers. These are capable of self-fertilizing themselves.

Other plants have a block that prevents pollen from their own flowers from fertilizing themselves. These require a cross-pollinator to produce fruit (ex: apples). In these it is worth encouraging visitations by pollinators by creating conditions that attract them. It is also worth planting such pollinators down wind of the target of prevailing winds during pollen season.

There are plants that have separate male and females of their species. Male flowers or female flowers (ex: Kiwi vines). Males do not produce fruit, but their presence is required for females to produce fruit. Still others will self pollinate but fruit yield will increase if a pollinator is nearby.

And other plants just produce fruit without any fertilization process occurring.

What to plant?

Dependent upon planting location, total sunlight, shade, climate, humidity, soil. Generally there are three growing seasons and one dormant season (i.e, winter) in any location. I live in an area (Phoenix, AZ) where things can grow year round. In areas with long winters growing seasons are short and crops must be planned accordingly, along with a long term larder for

Continues on Page 20

Continued from Page 19 - General Considerations in Fruit, Nut and Vegetable Production (Part 1)

storing food through the winter (generally Nov. to March is nonproductive). Some varieties are adapted to cold better than others and ripen quicker than others and are suited for colder climates. The kinds of food that store well must also be planned with their crops ending in the fall harvest. Areas with a long winter may also be supplemented with heated greenhouse (expensive) and indoor container growing. The spring plantings can be sped up with transplants and cold frame or row covers to early start plants and thermal blanket protection over them at night.

Seeds (annuals) can be kick started in the end of winter inside the house under grow lights and heat pads or in cold frames or greenhouses.

Where are the pollinators coming from? Where are the parasitic pests coming from? Where are the beneficial insects coming from? Some plants attract life, others repel. Knowing this can assist your multiple crops development and survival.

Knowing all of this allows planning to adjust conditions to hopefully maximize productivity and minimize food waste. And like a lazy gardener, you want to set things up to run themselves as much as possible. Farming is hard work. I hate hard work!

Contacting your local [county extension](#) agent, [master gardeners](#), university agricultural depts [keep in mind they are there to support farmers and their crop/row techniques may not be applicable to you], look for edible gardening clubs (most are for flowers), hit the Internet (blogs), local nurseries (the very good ones invariably seem to be the family run non-chain ones), local permaculture web sites, hit the books. Magazines [ex: [Backwoods Home](#) magazine, [Mother Earth News](#), and [Sunset](#)] and journals. Find out what does and does not grow well (or at all) in your area---don't waste your time, money repeating the mistakes of others. Don't make life harder for yourself initially. Plant for success. With success you can try other species or varieties with the hope that they too will be successful after you are up and going. 🍷

Next month Part 2: Edible Trees (fruit and nut)

Powell Gammill is a certified Permaculture Design Consultant whose interests lie in creating an environment in which food is grown to benefit families and draw neighbors together. Where dependency on outside resources is diminished. And properties are improved with use instead of being depleted.

[Make a Comment](#) • [Email Link](#)
[Send Letter to Editor](#) • [Save Link](#)

The Garden Pool: A subterranean aquaponics greenhouse

By Powell Gammill

[Make a Comment](#) • [Email Link](#) • [Send Letter to Editor](#) • [Save Link](#)



<http://GardenPool.org> - Learn how we converted an old swimming pool in to a way to feed our family. We use organic aquaponics to grow unlimited tilapia, chicken eggs, fruit, veggies, & herbs. We had planned to be food self-sufficient by 2012 but we made it by mid-2010. If we can do this then anyone can.



I am a huge fan of the [the Garden Pool](#). What is the Garden Pool?

It is a couple's vision of a self contained closed loop food production system made in a swimming pool using aquaponics and powered by solar energy. The gist of the idea began when Dennis and Danielle McClung bought a Mesa (think Phoenix weather), Arizona home with a run down swimming pool in need of either removal or restoration. With a new mortgage they didn't have the money for restoration, and removal seemed like a shame not to mention it was still going to cost them money.

Garden Pool Family

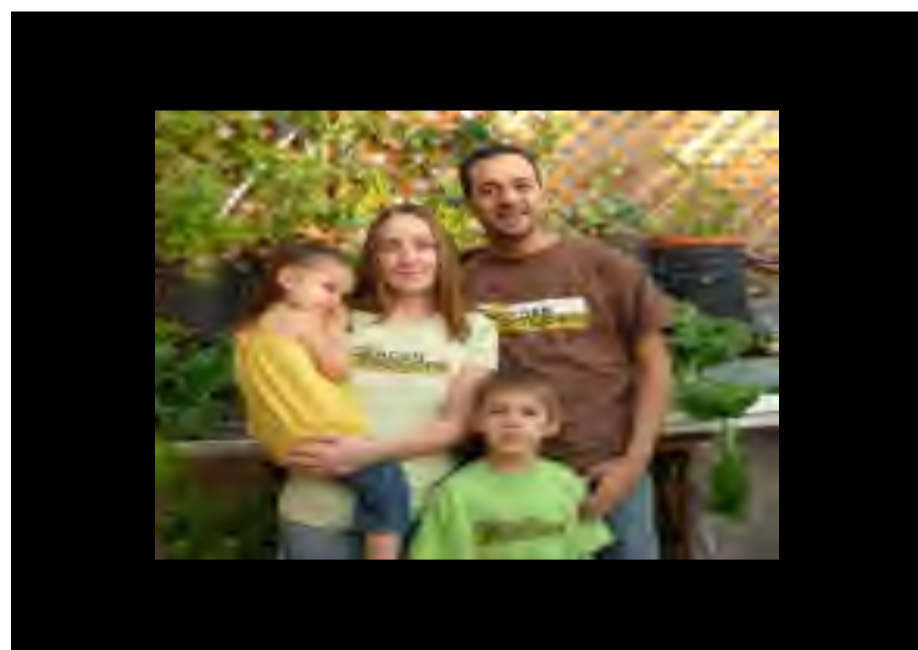

The idea of creating a garden in the pool, sort of a subterranean greenhouse popped into Dennis' head. The rest is history.

The Garden Pool feeds a family of four with 8 fresh chicken eggs a day, unlimited tilapia fish, organic fruit, veggies, and herbs 365 days a year while using 90% less water than conventional farming methods.

The garden pool is so much more than just this unique attraction. It is a self help website filled with clever ideas shared so that you too can build from inspiration. I will mention the do-it-yourself and educational video projects later.



[The Garden Pool](#) is a 16 foot by 30 foot swimming pool enclosed in a PVC structure UV resistant polyfilm translucent canopy that raises the high at the "deep" end to about 15 feet. This

main structure took two days to build and many months to refine the process inside. Since this is Phoenix, Arizona there is an evaporative cooler that keeps the interior about 15 degrees cooler than the outside in the summer. Additionally shade blankets are spread over some of the structure in the summer to keep temperatures down. Inside the structure maintains a pleasant lake side humidity and odor. At the bottom of the pool is a 3 1/2 foot deep (6,700 gallon) pond measuring 16 foot by 16 foot. About a third of the water source was recycled greywater from the bathroom showers/ sinks and laundry machine...new projects now seem to have diverted this reused water.

They spent \$1,500 on treated 2x6's & 2x4's, a 1/2" braided steel cable, a 20'x40' 12mil clear UV treated tarp, a 3,000 cfm evap cooler, 90 Watts Solar, a Power Inverter, a Marine Battery, 5 gallon buckets, storage totes, scrap wood, redwood lattice, lava rock, drip irrigation tubing, rain gutters, hydroton, air stones, 2 air pumps, 2 pond pumps, etc.



Floating on top of the pond is rapidly growing [duckweed](#) and other pond plants: this helps provide shade and cut down on evaporation in the summer. Additionally the volume of water is greater in the summer as well to keep the water from getting too hot. These plants are involved in [bioremediating](#) the water. Duckweed has a high protein content and is edible. Growing on the bottom of the pool is algae.

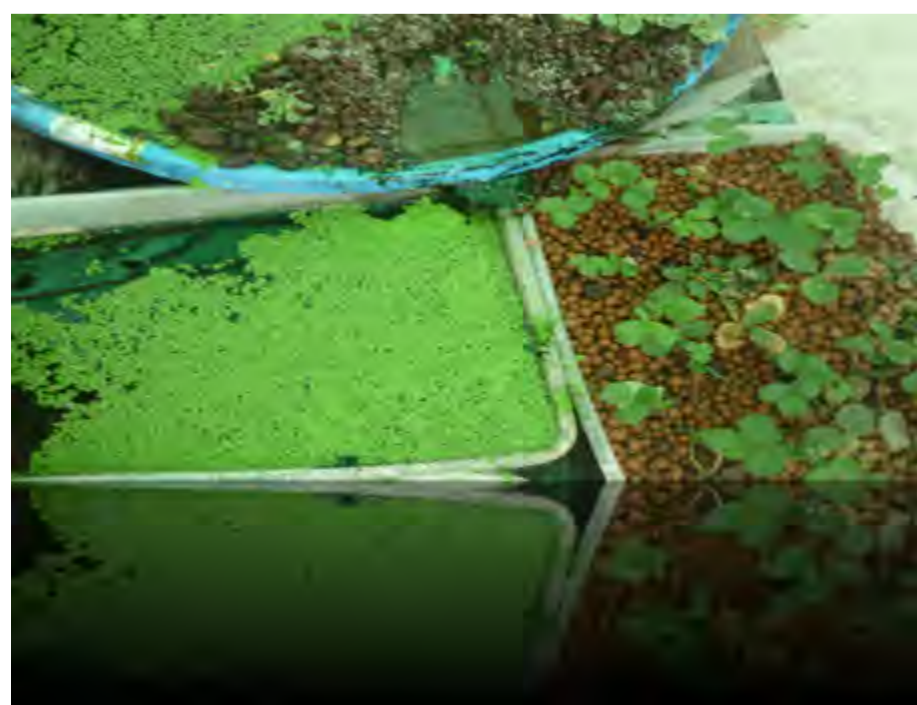

Swimming in the water are [tilapia](#), some of the fastest growing popular buttery tasting warm water fish, which eat the algae and the duck-

Continues on Page 22

Continued from Page 21 - The Garden Pool

weed. A single mature female can have 1200+ babies every 4-6 weeks. A [tilapia](#) matures from egg to harvest size (1.5 lbs) in only 6-9 months. They have a small head so most of the fish is fillet. They grow very well in very warm waters with low oxygen requirements. A channel catfish patrols the bottom and eats many of the small tilapia fingerlings as a population control. Garden pool also has 2 tanks to raise young fry and fingerlings.



Tilapia would eat any mosquitoes near the pond and the water is constantly flowing in the aquaponic setup which prevents the growth of larvae. They monitor the water daily for pH, dissolved oxygen, biochemical oxygen demand, temperature, turbidity, nitrate, nitrite, phosphate, and coliform [such as *Salmonella*] indicator bacteria.

Aquaponics requires less resources than traditional farming by creating a sustaining recycling system. Energy usage is offset by taking advantage of solar power, thermal mass, and gravity.

[A chicken coop](#) is built over the pond, with the [roosting egg laying hens](#) directly pooping into the pond at night through a chicken wire floor. In the day the backyard is the chicken's kingdom shared with two goats and a solar oven. Because the fish and chicken waste are absorbed by the plants, the up keep of the animals may actually be easier than a typical fish tank and coop. The chick eat duckweed and other pond plants.



Additionally Dennis designed a [black soldier fly](#) (BSF) larvae [chicken feeder](#) that rocks! BSF larvae rich in calcium that egg layers need. They feed on your garbage composting it and producing a nutrient worm juice, they secrete a pheromone that repels flies, and when they get to a point in their maturation cycle they naturally climb. Dennis thoughtfully added a ramp for them to climb up and drop into a chicken feeder down below.



They have recently added four ducks to the pond.



The water is also constantly recycled and this uses 90% less water than conventional farming! You also don't have to spend time watering plants. You do not have to weed as they do not grow in a controlled greenhouse-like environment. Organic Food – With your produce receiving nutrients from your fish and chickens, not only will the resulting crops be vibrant, fish healthy, and eggs fresh, they will be organic too! Less land is needed to produce crops in an aquaponic system and crop yield is faster.

[Aquaponics](#) versus [hydroponics](#) (versus [aeroponics](#)). The McClungs originally started out with hydroponics in mind. Here nutrient waters circulate through porous beds. The advantage is no weeds and easy planting, easy harvest. But they quickly realized it was expensive with weekly additions of supplements to the water that made you dependent upon a supplier. In search of a solution they came across aquaponics which uses fish waste water to circulate through plant beds giving the same benefits without the expense or supplier dependence. And you can eat the fish.

BIOFILTRATION PROCESS

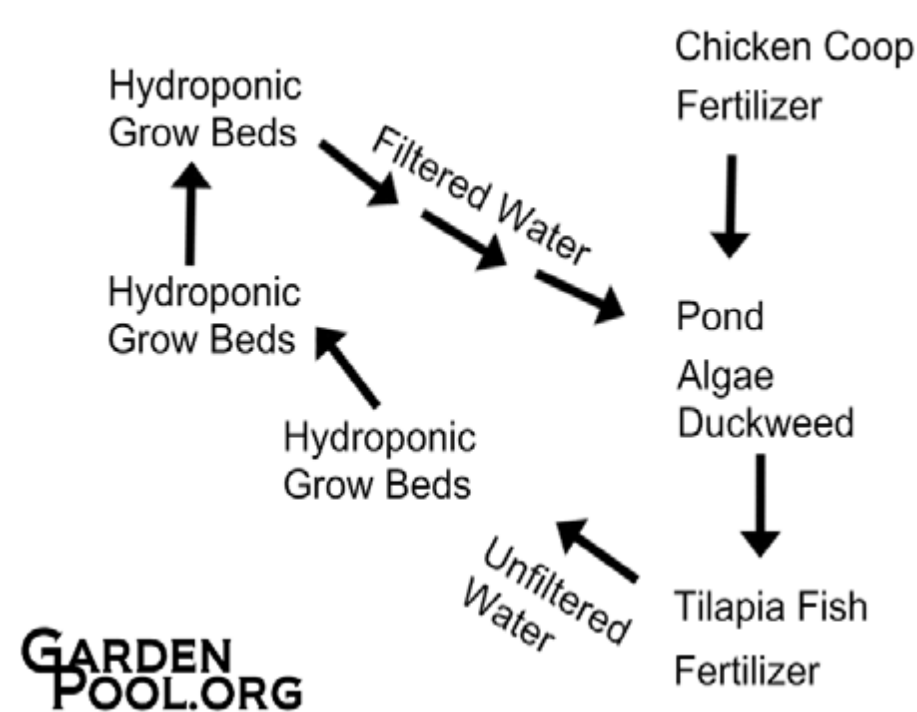

A solar panel powers the internal lighting (LED), fans and pumps. The evaporative cooler still requires the power grid, but they are hoping to add more solar panels and a more efficient cooling system in the future to go completely energy independent in the garden pool.

They have these long rain gutters that they hang up throughout the pool area. The gutters were originally filled with pebble sized lava, but they switch to [hydroton](#) (expanded clay). Both have a porous structure which supports a home for vast microbial communities that not only clean the fish water but fix nitrogen to support the plants. Water is pumped up from the pool and circulated through the hydroton beds. Plants are directly transplanted into these beds or more conveniently started as transplants on a seed transplant cube/plug and then transplanted. The water also circulates through a series of hydroton containing 5 gallon buckets and kiddie pools. The variety of plants being grown is mouthwateringly impressive.

Continues on Page 23

Continued from Page 22 - The Garden Pool



The McClungs are clever in finding solutions to one problem after another, and the result seems to be problem solved with a product being produced. And they share. I see no reason why their garden pool cannot be adapted in many other areas of the planet, and it doesn't even need a pool.



Danielle video showing [how to clip chicken wings](#). [PS: Her chicken course is well worth taking even if you have already attended other's similar course.] 🍷

[Greywater project video](#)

[Shower greywater video](#)

[Shelfponics video](#) Dennis' DIY project that inspired the planet. And [barrelponics](#). Got fish?

[GP on Youtube](#)

[GP on Facebook](#)

[GP on Meetup](#)

[Make a Comment](#) • [Email Link](#)
[Send Letter to Editor](#) • [Save Link](#)



Learn how we turned our pool in to a self-sufficient garden to feed our family.

Independence Through Gardening

By Pam Perry

[Make a Comment](#) • [Email Link](#) • [Send Letter to Editor](#) • [Save Link](#)



GROWING and ready to harvest this June and July in the vegetable garden were tomatoes, tomatillos, peppers, onions, garlic, and cucumbers. These all make a great gazpacho! Eggplant and more tomatoes, onions and garlic for eggplant polenta with spicy tomato sauce make a great summer supper dish. A few squash were ready, a couple of melons, too. Beets remained from the late planting for summer borscht. Remaining leeks pair with potatoes for soup, good cold or warm. Carrots are sweet and oh so tender! Melons too are sweet and so satisfying on hot summer days! The summer bean crop of black eye peas, seeded a month ago are about to bloom as are the yard long beans. Summer greens, including chard, New Zealand spinach, Basella Malabar, purslane, yes, purslane and assorted vines are ready for summer salads. The multiplying onions are recovering nicely from being divided and replanted and the surplus curing on the back porch will keep for the rest of the summer! *Where* is this garden you ask? Right here, in Phoenix, AZ!

In the low valley we can plant and harvest something almost every day of the year; a rather diabolical idea for gardeners who only know a 70-110 day growing season to prepare soil, plant, nurture, harvest, consume, or put by. Anyone with several hours of sun and water can garden every day of every month in the low desert. New to gardening? No problem! You have no old habits to change!



Gardening here is almost like gardening everywhere. Start with these steps:

- It is different here! Study resources available to **low desert** gardeners.
- Select a location for your garden. Vegetables require 6-8 hours of sun, minimum. Yes, even in the summer. Front yard, side yard, back, neighbor's yard, community garden plot, 6-8 hours of sun. Morning sun is better, but 6-8 hours minimum is a must!
- Vegetable gardening requires a water source. We can grow desert adapted varieties, but vegetables are not desert adapted plants. Irrigation happens, all year long.
- Once a site is selected soil preparation commences. After all, vegetables are not desert adapted plants! We add inches of compost, nitrogen and phosphorus fertilizers, dig them together and rake smooth!
- Irrigation is installed
- Crops and varieties suitable for the season are selected, planted, nurtured, harvested, and consumed. Piece of cake!

Want more? Study your landscape. Can you add fruit trees, do you have mesquite trees? Is there room for a few hens, rabbits, do you live where goats, sheep, llamas, are welcome? How involved do you want to be in your own food production?

Make your Garden

Site selection should include an irrigation source and 6-8 hours of sun. It could allow for expansion. Start small, grow your garden with experience, your needs and interests. While a goal may be to produce 100% of fresh vegetables consumed in a household, meet your success in increments. The challenges of gardening in extreme climates can overwhelm even the most experienced gardener. If you take on more than you can reasonably manage discouragement comes easy! The weeds and the bugs and the daily grind will can undermine even the most dedicated soul! Start with a few containers, a small raised bed or garden; when that is not enough, build on. Grow the garden along with your skills and the seasons! The low desert is an extreme climate! And remember: Grow things you like to EAT!

Garden layout and design. Paths and planting areas should be separate and permanent. Allow space to get tools and equipment in, thru and to the garden! If you want raised beds, build them. You can use found materials or materials that are aesthetically pleasing and compliment current hardscape. However, do not use treated timbers, recycled rail road ties, old phone/power line poles... anything soaked in creosote! I have some 2 X 12 pine boxes that were hammered together 10 years ago. They still work. I do suggest screwing wood together. You can use cedar or redwood, but inexpensive pine is fine. Either way you should be able to reach the middle of the bed from one side or the other. Use a soil mix at least 50% compost and 50% good old native, desert soil. Some folks like to add some pumice for porosity. Procure containers if you want container gardens. 5 gallon buckets are about as small as you should use; 15 gallon tree pots or larger are better... all should have bottom drainage. Excess water must be able to exit the container! Install some sort of an irrigation system for your garden. This may be a nozzle and a garden hose or a sophisticated timer, valve, schedule 40 PVC, 5/8 tubing and emitter operation. This, too, should be expandable as your garden evolves to include more plants.



Make lists of vegetable crops you like to eat. Then select short season varieties with characteristics that appeal to you from within these crops. Information on the incredible diversity of all kinds of vegetables and fruits is

Continues on Page 25

Continued from Page 24 - Independence Through Gardening

available in seed catalogues. Use them for research! Just a word from experience: do not get too carried away, right off! There is time to try many, many plants! Don't let your eyes and dreams get bigger than the garden. It's so easy to do! Talk to friends and neighbors and your local independent nurseries. They too, can help select great varieties to begin with.

Three unique planting seasons. The easy one is the fall season. Call this the green and leafy season: lettuce, kales, collards, carrots, turnips, onions, spinach and chard, beets and carrots, oriental greens, etc all thrive during this season. Broccoli, cauliflower, cabbage, fava beans, and all kinds of peas are fall planted. Harvesting begins well before Thanksgiving! Planting can actually start during monsoon, (that would be now!) but most crops go in September thru November, from seeds or little plants someone else has started. Find recommended planting dates in the planting calendar available thru U of A Cooperative extension or the Permaculture group.

Fall days are pleasant, the light is not too intense, and the nights are cooler. After the equinox, nights get shorter and shorter, and cool considerably. Plants with maturity dates of 60-90 will be ready for harvest before the solstice, when we experience our coolest weeks, when daylight is very short and plants become dormant. For this season plant short season, 50-90 days-to-maturity, cool tolerant varieties of crops.



January begins a second cool season, but these days get longer and warmer! Our frost date in Phoenix is generally about February 14, but do not take that for granted! This season we make a second planting of many of the green and leafy vegetable crops to harvest into late spring. We can also plant what might be described in other regions as 'summer vegetables'. Tomatoes, peppers, corn, squash, potatoes, beans, cucumbers all come quickly with produce to harvest! Day time temperatures get HOT. Look for varieties that are described as "heat tolerant". This is a fun season, plants grow quickly and favorite vegetables are in good supply. There is nothing like a warm-from-the-sun homegrown tomato! Again, refer to planting calendars for the low desert for recommended planting dates, and select varieties which mature quickly, and are heat tolerant.



Then we move to the long... long... long... hot, summer season. Yes! You can plant and harvest thru the summer! Sweet potatoes provide ever widening seas of cool green in the garden, making tubers to harvest in September,

October and November. Yard long beans and black eyed peas love the heat. Pick them tender as green beans or allow the beans to mature for soup and bean dishes. Armenian cucumbers, melons, and squash take the heat and produce. Basil loves the heat and offers sweet and savory flavors for our summer salads. Okra, the world's most maligned vegetable grows gangbusters; eggplant looks great at 118 degrees, and offers a continual harvest. You do not have to settle for that 2 lb aubourgine at the chain grocery; long, slender, green or sweet purple ones compete in flavor with lovely lavender or pink on white skinned fruits. They are as pretty as they are tasty. Harvest them small and often. Cultures from Mediterranean climates all have great recipes for cooking this vegetable. You will need many! Eventually we run out of tomatoes, slicing cukes, the potatoes need harvest, we consume our corn, squash bugs infest the squash, and we visit the garden early in the morning, and maybe just before a late supper to harvest.



Come monsoon season we can plant again, corn, beans, fall cropping summer squash, maybe a fall bearing tomato plant, "and the seasons, they go 'round and round!'"

With all this in mind make a planting plan.

Pencil in the vegetables you want to grow into the proper time frame according to the planting calendars, and seasonal challenges. Study spacing suggestions... and design the garden. Just be sure to keep track of your local planting calendar, when you make your garden plan. Many seed catalogues and garden supply companies are offering interactive garden planning programs on their websites. This is kind of fun and allows you to get a feel for spacing, and production.

Go out and dig your soil.

Soil preparation: Ya gotta do it. Go dig the dirt. Dig. If you are mechanical, and have lots of space, rototill. But only where you plant to plant. Do not disturb the pathways! Once soil is loosened a shovel or so deep, add 3 to 6 inches of good compost, some manure perhaps, and a sprinkling of a balanced fertilizer and dig again. Rake it level, remove large rocks and general junk. Use a steel tined garden rake, not a leaf rake. Set up your irrigation, run it, re-level the bed, and you are ready to plant! If you leave the pathways undisturbed, you have less work, much less.

All this digging helps integrate the compost and fertilizer. It introduces lots of air spaces to the soil. Plant roots need oxygen as much as they need water. Our native soil is naturally compacted. Digging helps change this. If you are making raised beds, the soil mix to fill them should be 30 – 50 percent native soil. Use compost and perhaps some pumice as the remaining ingredients.

Good old Arizona soil is full of minerals and nutrients. We have some of the best, nutrient rich soil found anywhere. Yes, it is a clay soil; this is the result of eons of erosion. It holds water well, too well sometimes. It is heavy and

Continues on Page 26

Continued from Page 25 - Independence Through Gardening

dense and hard to work. Moisten it, but do not let it get soggy. It is easier to work if it is moist. Wait and allow it to dry out if you have accidentally oversaturated it. Soil should feel as moist as a wrung out sponge.

Our soils lack organic or decomposed dead plant matter. We call that stuff compost. So, we add compost. Lots of compost. Pumice or perlite will help aerate the soil, but compost is the primary component needed for soil preparation. As this organic component is introduced to the soil, the biodiversity of living organisms which brings soil alive begin to evolve and continue the decomposition process, rendering nutrients accessible at the molecular level to the plant roots.

There are many, many products sold as soil amendments. Some as powders, some liquid, all with interesting claims! Most of these come from other climates, other soils, and may have a positive impact there, but **nowhere** is there research based, quantified documentation of how they really affect gardens in the low desert. Spend your money on plants. Compost, maybe manure, some fertilizer with nitrogen, phosphorus and potassium in equal amounts, perhaps some soil sulfur are more than adequate to get the garden growing. Happy planting!

Irrigation must reflect the season, the maturity of the plants and the soil mix. Raised beds and containers require a different approach than gardens at ground level. There is no one rule to apply for successful irrigation. It is ever changing and requires vigilance on the part of the gardener. But as you go out to harvest, you will learn to observe your plants and make those adjustments as needed for the continued success of your garden. Water should saturate the soil of a vegetable garden 12-18 inches deep, or to the bottom of the container. As this reservoir is depleted, irrigate to replace the water and keep plants healthy.

Is it possible to become less dependent on the world of mass produced everything; achieve some level of self sufficiency? Growing your own vegetables and even fruit as an alternative does not necessarily mean doing without! You too, can discover self sufficiency at one level: providing some, maybe more, maybe less, of the food you eat from your own little patch in Phoenix. Growing a vegetable garden, populated with other plants which offer edible parts falls within the scope of reasonable, which can provide fresh, safe, nutrient dense food. Knowing what these foods really taste like, fresh from the vine, grown in healthy soil they are great eating and good for you! Concept.



Training Manual, on line, free. This information is research based, quantified, and developed for our particular soils and climate challenges. Two particular publications: *10 Steps to a Vegetable Garden* <http://cals.arizona.edu/pubs/garden/az1435.pdf> and the *Vegetable Planting Calendar* <http://cals.arizona.edu/pubs/garden/az1005.pdf> apply to starting and growing a vegetable garden.

Books too are available. Master Gardener press offers Desert Gardening for Beginners, a short, but comprehensive look at growing food plants and landscape care that speaks to both expert and novice alike, whether you are a native, or just recently transplanted to the desert! George Brookbank's Desert Gardening is a great resource. Out of print for a while, it has been re-released. Brookbank, a professor at U of A, was at heart a gardener, and there is not much he did not try to grow. He has quantified and summarized a great deal of information for us! This is a great source for not only vegetable gardening, but home orchards and small fruits as well. "Dave the Garden Guy", Dave Owens, long a personality on local television has published the Garden Guy and Extreme Gardening. Strong on organic ideas and suggestions these are great books to help you understand what gardening is all about. Magazines make great resources. Folks swear by the classic for small farmers and home gardeners *Rodale's Organic Gardening and Farming Magazine*. *Sunset* brings us a California attitude. All offer great information, but do make sure you cross reference suggestions with low desert experts. What works in many places may work well here, just at a different time, or with adaptations! Locally published *Phoenix Home and Garden* offers consistent excellent gardening information and highlights great local gardens.

Additional information can be found thru the local Valley Permaculture alliance. Phoenix-permaculture.org These gardeners are adapting many regional traditions to our particular conditions, with passion. They too publish a planting calendar, with bright, cheery, colorful graph-

Continues on Page 27

Continued from Page 26 - Independence Through Gardening

ics indicating not only time for planting but for harvest. They offer a range of classes and educational opportunities, a website, blogs, posts, classes, seminars, and garden tours.

Square foot gardeners take French intensive gardening to a new level, packing as much into a small space as possible. A&P, a local nursery, has developed a raised bed square foot garden kit, and a nutrient dense soil specific for the low desert adapted to the requirements of square foot gardening. Couple that with a planting calendar and you are well on your way to a great harvest on a small patch of real estate!

Container gardening is an option for small areas, limited sunshine, and little time. Portable and manageable, a great deal can be harvested from a small space using containers. Many varieties of vegetables are bush, or dwarf, or determinate, fitting well into small spaces and offering a bountiful harvest. Earth boxes, a self watering container system is similar to square foot gardening. These can be easily moved by a couple of folks to follow the sun. Should one not have a lot of space or soil to dig, they make great container gardens. Clever folks can adapt



the engineering of the system to 5 gallon buckets and other containers.

Vegetable gardening classes abound in the valley with Permaculture, U of A, nurseries, garden centers, garden clubs, Desert Botanic Garden, other public gardens, and various cities offering classes throughout the year. Master gardeners present seminars every day at each of the 5 Maricopa County home shows held in Phoenix and Glendale each year! For the next show go to: maricopacountyhomeshows.com. You do not have to discover the wheel all by yourself! Last but certainly not least, with a few key strokes and the click of a mouse, seed and garden catalogues offer a wealth of information about varieties of vegetables, small fruits and fruit trees. They provide gardeners a resource for growth habits, maturity dates, varietal characteristics, disease and pest resistance, taste, flavor, vigor...of any vegetable you might want to grow! Some have interactive design programs to help you lay out your garden season to season. Many offer helpful videos as a component of the online source, demonstrating soil preparation, planting, nurturing, and harvesting techniques. Use those seed catalogues!

Johnnyseeds.com, botanicalinterests.com, seedsavers.org, seedsofchange.com, rareseeds.com, cooksgarden.com, seedsofindia.com, territorialseed.com, gardenerssupply.com native-seedsearch.org are just a few of the many seed sources available to gardeners! Our independent, local nurseries and garden shops carry good seed selections and young plants ready to transplant into your gardens. Shop often and frequently. 

[Make a Comment](#) • [Email Link](#)
[Send Letter to Editor](#) • [Save Link](#)

The Garden Room – Gardening for Life

By Barbara Peterson

[Make a Comment](#) • [Email Link](#) • [Send Letter to Editor](#) • [Save Link](#)



GARDEN like your life depends on it – because it does!

In this age of rampant contamination of our food supply by pesticides, toxic sludge, radiation, and genetically modified organisms (GMO), as well as increasing regulations restricting family farmers and people that merely want to use the space in their yards for something useful such as growing food, we would all do well to start learning how to plant a garden, and save the seeds from those crops for future plantings and to share with neighbors and friends so that if one person gets shut down, then others can share their saved seeds and the garden can be started right back up again.

This is guerrilla warfare using seeds as weapons of mass deliverance.

How we started our guerrilla warfare gardening project

First, I found some non-GMO, non-hybrid seeds. I asked the local feed store what brand of seeds they carried, then looked up the brands on the Internet to find out who owned the companies, and if Monsanto had anything to do with them, then chose the non-Monsanto related brand.

We started out with a small outdoor garden, growing things that we were told would grow



without too much expertise, since we were just beginners. We fertilized the garden area with aged horse manure from our own horses, and planted spinach, beets, carrots, cabbage, mustard greens, onions, swiss chard, lettuce, and radishes, then watered diligently by hand. We were not disappointed, and actually had a decent harvest our first year. This was encouraging.

After that, we experimented with other crops such as zucchini, butternut squash, cucumbers, and tomatoes. Since our growing season is so short, the squash, cukes and tomatoes froze. This was disappointing to say the least, but we learned.

I then went on the Internet to find out how to save and store seeds for future plantings. I found that it is necessary to get non-hybrid seeds, and wanting to keep everything organic, made sure that I got [heirloom organic seeds](#) from a reputa-

Continues on Page 29

Continued from Page 28 - The Garden Room – Gardening for Life

ble company. Here are instructions for harvesting and saving your seeds: [LINK](#)

The indoor garden



Because I love tomatoes, cucumbers, peppers, and butternut squash, this year I decided to do something different and start an indoor garden because these crops simply do

not do well outside unless you have a greenhouse, hoop house, or other type of covering for them. Since we have a spare bedroom, it just seemed logical to convert it into a garden room.

We built a three-tier bench out of scrap lumber in front of the window, and installed a simple fluorescent grow light under the top shelf.



I used pie plates with clear plastic tops and plastic containers from the supermarket as mini-greenhouses to start the seeds, then transplanted them into large cans.



There are two other walls on which to build shelves, and we plan on doing that just as soon as possible to house the many plants that I started. We also plan on installing at least three more grow lights to make this room an all-year grow room, with fresh veggies available year-round. This will be accomplished by staggering the planting schedule. The tomatoes will hang [upside down](#) from the ceiling because they seem to do best that way, and it saves space in the room. [Here is a link to some information regarding grow lights.](#)

Future plans

In the future, we plan to expand our outdoor garden to include an automated sprinkler system, which will cut down on the manual labor. The indoor garden room will eventually contain its own water supply with utility sink, and a timer for the lights. The closet in the garden room will contain shelves to store seeds, supplies, and anything else I need to keep the garden growing.

If we can do this, so can you. I encourage everyone to [start their own project](#), whether it is an indoor garden room like ours, an outdoor garden, greenhouse, [window garden](#), [hydroponics garden](#), [vertical garden](#), or anything that your space will allow. The time to start is now, because if you are hungry, there is no time to learn how to do this. So take this time to prepare because we are quickly becoming so dependent on imported food that prices are apt to skyrocket out of control and out of the budget for many of us. What will you do if you go to the grocery store and a loaf of bread costs \$10? I know what I will do. Plant more seeds and learn to live on fresh veggies for the majority of my diet. We can survive the coming crash, we just need to get resourceful and learn how to grow our own food in the face of all opposition. After all, *this is guerrilla warfare using seeds as weapons of mass deliverance.* 🍷

© 2011 Barbara H. Peterson – all rights reserved
 Website: [Farm Wars](#)
 Blog: [Speak Truth 2 Power](#)
[Writer on Freedom's Phoenix](#)

[Make a Comment](#) • [Email Link](#)
[Send Letter to Editor](#) • [Save Link](#)

Prepping with an Urban Garden

By Gary and Verda Gagnon

[Make a Comment](#) • [Email Link](#) • [Send Letter to Editor](#) • [Save Link](#)



WITH our attention on inflation, the economic collapse and the rising costs of the dinner table, along with our daily listening to [Declare Your Independence with Ernest Hancock](#) that motivated us to join the Agriculture Club at our home in Sun City West. We purchased the improvements made on an existing plot for seven hundred and twenty five dollars. There are currently two hundred eighty four plots which makes it the largest community garden in Arizona and one of the largest in America. The plot measures sixteen feet by thirty two feet and is fully enclosed with an animal proof cage made of three quarter inch chicken wire with a steel frame. It has raised beds made of two by four's. Some members have as many as four plots but we decided to only go with one plot while we gained experience.

Even though the club has rototillers available we decided to purchase a light weight *Mantis* rototiller which weighs in at only thirty four pounds. It is much easier to handle in the raised beds.



Over head shade cloth gave the garden a break from the direct sun, while the corn in the open plot next to ours needed all the sun it could get.



We had done some container gardening at our former home in California but it has been a wholly different proposition leaning the tricks of raising a successful garden under the extreme conditions of the Valley of the Sun. Fortunately our friendly neighbors at the Agriculture Club have been most helpful. The first thing they gave us was a list of planting dates and which plants do best in the Spring or Fall seasons. We learned the value of the judicious use of shade cloth as



the temperatures soar. *Extreme Gardening by Dave Owens*, which helped us understand how to grow organic in the hostile desert climate and *All New Square Foot Gardening by Mel Bartholomew* are two of our heavily relied on resources. We heartily recommend both of these books and find them to be indispensable in the low desert conditions we have here.



Wall O' Water

The cells around the outside of this plastic sleeve are filled with water, which will absorb the sun's heat and keep the plants warm. This cozy little igloo helped the pepper plant within survive the cold snap that hit our area this last spring. Wall O' Waters can give, as much as, 2 to 3 weeks jump on getting plants into the garden and extend the growing season.

Growing organic and avoiding the use of pesticides is an important issue for us. In the early Spring, Wall O' Waters help protect the tomatoes and peppers from frost. Marigolds were planted and fly traps were hung to control insects. Flowering plants helped to attract bees which are essential to ensure pollination and improved yields. We fertilized with steer manure, blood meal, bone meal, sea weed emulsion and fish emulsion. The importance of building a good soil base can not be over emphasized along with a proper watering plan. Deep soaking to get the roots to grow deeply seemed to work best. Several different soap solutions were used, as recommended in *Extreme Gardening*, to keep the bugs off the leaves. All of these methods were met with reasonable success. I would estimate we were able to keep our losses down to 20% of the crop being consumed by the bugs with-

Continues on Page 31

Continued from Page 30 - Prepping with an Urban Garden



This jumbo potato bag has approximately 8 potato plants. At this point it is still folded over but as the plants grow the bag is expanded and more dirt is added. No harvest yet!

out the increased dangers of pesticide use. Our own improvements were added to the plot by installing a sink with a spray nozzle and an in-line water filter. The vegetables harvested could be washed and the filtered water drained back into the garden beds. Every little bit of water conservation helps. Paving stones and carpeting were added in the walkways, to keep from tracking dirt and from sinking into the soft rototilled earth, while working the garden. Cages and trellises were added for the tomatoes, beans and cucumbers. We tried growing the potatoes in a bag to increase the yield. Along with strawberries in hanging baskets to utilize the overhead growing area. Going vertical is always a good idea. Not only does it give more square footage it keeps the fruit off the ground. An added bonus is cucumbers and melons are much less likely to spoil when not allowed to rest on the damp soil. The muskmelons that were planted have attached themselves to the chicken wire and grown up the side of the cage and onto the roof. It is amazing how large the fruit can get and still be supported by the vine. Not willing to take a risk, slings were fashioned from shade cloth and attached to the chicken wire with zip ties. It is quite a sight.



Pickled beets are ready to be placed in the water bath canner as soon as the water comes to a rolling boil.



The speckled blue enamel water bath canner is still a great investment. They can be purchased new, for as little as \$18 but can be found at estate or garage sales for even less.

The time to be spent in the garden was grossly underestimated because of the pleasure we gained working the crops and watching them grow. Verda and I spend 1 1/2 to 2 hours every other day watering and weeding not to mention harvesting.

Many different plant varieties were planted to determine which produced and tasted best. The next garden will feature those varieties and will be planted in greater quantity to produce yields sufficient to allow more freezing, canning and dehydrating for the pantry. Next season there will be a map of the garden detailing the layout of the items planted, the date planted and the

normal maturity date of each plant. This should help in knowing exactly when to harvest.



There are numerous dehydrators on the market. The newer ones have circulating fans and will dry quicker and more even. This one is 20 years old, has no fan, and works just fine. Our back up is a sun dehydrator with mesh screening that can be hung outside on the patio and is also very effective. After these tomatoes are dried they will be vacuum sealed in a canning jar. This is one batch which is an assortment of different sizes and types of tomatoes. Approximately 20 tomatoes per batch.



This jar is approximately 2 batches of dehydrated tomatoes. It certainly saves space in the pantry!



Typical every other day harvest from the test garden.



Canning Jars of Sweet Pickle Relish, have been processed, and are ready to be removed from the water bath canner.



Canned goods must cool for 12 to 24 hours without being moved to insure a proper seal.

Tomatoes were dehydrated and vacuum sealed in canning jars. Pickled beets, sweet pickle relish, pickled carrots and refrigerator sweet pickles were all preserved out of this years test garden. We were able to try these techniques successfully and will be ready to go with the larger yields of the next garden. Important note: Do not try to can tomatoes if they are overripe as they will not can properly due to low acidity. This is where a dehydrator comes in handy.

Continues on Page 32

Continued from Page 31 - Prepping with an Urban Garden



A well stocked pantry from your garden helps cut grocery costs.

Here is a list of what we were able to plant in our plot.

Artichokes, Bush Beans, Kentucky Wonder Pole Beans, Scarlet Emperor Pole Beans, Bush Wax Beans, Detroit Red Beets, Broccoli Rabe, Nantes Coreless and Baby Little Finger Carrots, Cauliflower, Straight Eight and Pickling Cucumbers, 5 varieties of Green, Red and Yellow Bell Peppers, Hungarian Yellow Peppers, Anaheim Chiles, Jalapeno Chiles, Mesclun Sweet Salad Mix, Heirloom Red Spotted Romaine Lettuce, Red leaf Lettuce, Bright Lights Swiss Chard, Red Winter Kale, Crooked Neck Yellow Squash, Zucchini Squash, Olympia and Teton Spinach, Fourteen Varieties of Tomatoes, Tomatillos, Diakons, Crimson Crisp and Red Head Radishes, Muskmelon, Bunching Onions, Chives, Cilantro, Sweet Potatoes, Yukon Gold Potatoes, Oregon Sugar Pod II Snow Peas, Blackberries,



Sweet pickle relish was a great way to use up an assortment of Straight Eight and pickling cucumbers. Along with bell peppers and onions from the garden.

Blueberries, Raspberries and Strawberries.

I would estimate the yield on the Spring crop to be 200 to 300 pounds of fresh produce, not bad for a first effort. The sweet potatoes, African Climbing Spinach, and the Muskmelons will continue to grow throughout the summer. The other plants are being pulled and amendments added to the soil to prepare for the Fall planting. Keep building and improving the soil and it will continue to yield results.

Artichokes, Raspberries, Blackberries and Blueberries, which are perennial plants, will be left in place. A light fertilization during extreme heat will help the plants withstand the high temperatures.

Three of our favorite, go to cookbooks and canning guides are: *Ball Blue Book Guide to Preserving*, *Backwoods Home Cooking, an Anthology* from the *Backwoods Magazine* and *Growing and Canning Your Own Food* by Jackie Clay.

Jackie Clay is an amazing woman and is a true homesteader. Her advice is genuine and her recipes are wonderful. In addition to her many books, Jackie writes for *Backwoods Home Magazine*.

Home canned goods have a shelf life of several years and the process can prevent losing the items in the refrigerator and freezer, in the event, of a power outage. That is why it is important to learn and practice these skills now and not wait for a problem to occur.

Once items are processed and canned they require no refrigeration.

As you start your own garden, watch it grow to harvest, then can and preserve the fruits of your labor, you will experience a satisfaction and pride unknown to those who just march down to the local store to purchase items they neither know where they come from or what sorts of chemicals are in them. 🌱

[Make a Comment](#) • [Email Link](#)
[Send Letter to Editor](#) • [Save Link](#)

Open Source Ecology

[Make a Comment](#) • [Email Link](#) • [Send Letter to Editor](#) • [Save Link](#)



OPEN Source Ecology is a network of farmers, engineers, and supporters that for the last two years has been creating the [Global Village](#)

[Construction Set](#), an open source, low-cost, high performance technological platform that allows for the easy, DIY fabrication of the 50 different Industrial Machines that it takes to build a sustainable civilization with modern comforts. The GVCS lowers the barriers to entry into [farming](#), [building](#), and [manufacturing](#) and [can be seen as](#) a life-size lego-like set of modular tools that can create entire [economies](#), whether in rural Missouri, where the project was founded, in urban redevelopment, or in the developing world.

DEVELOPMENT TEAM:

We are an open source venture and as such we facilitate the collaboration of hundreds of online volunteers. The Development Team Wiki page is [Here](#).



MARCIN JAKUBOWSKI's TED TALK

FOUNDER AND DIRECTOR - MARCIN JAKUBOWSKI



Marcin came to the U.S. from Poland as a child. He graduated with honors from Princeton and earned his Ph.D. in fusion physics from the University of Wisconsin. Frustrated with the

lack of relevance to pressing world issues in his education, he founded Open Source Ecology in 2003 in order to make closed-loop manufacturing a reality. Marcin has been the lead fabricator, designer, blogger, and technical curator for OSE's prototyping thus far. His main interest is evolving to freedom by eliminating resource scarcity as the main force behind human relations - with the wise use of modern technology adapted for human service. He lives and works at OSE's land-based facility, Factor e Farm in rural Missouri. Marcin wakes up early, practices yoga, cooks indian food, and he's very ambitious. He has been selected as a [TED 2011 Fellow](#). See his [TED Talk on the Global Village Construction Set](#).

MEDIA DIRECTOR - ISAIAH SAXON



Co-founder and Director of [Encyclopedia Pictura](#), a creative team working in film, game design, architecture and agriculture. He has won numerous awards for his

music videos, including Video of the Year from DA&D, UKVMA, Antville, and Spin Magazine. [Esquire](#) called Encyclopedia Pictura "The Directors of the Future." EP is currently in development on their debut feature film, [DIY in 3d](#), which aims to be the new heroic myth of the Maker Movement in America. They are co-founding an augmented reality gaming startup as part of the DIY transmedia world. For the last two years, Isaiah has led an effort to build a unique hillside neighborhood in Aptos, California called [Trout Gulch](#). He lives and works there along with 17 others. He is co-founder of Trout Gulch Farm. At Open Source Ecology,

Isaiah directs the online information architecture, [explainer videos](#), presentations (including this year's TED Fellows Talk), and Kickstarter campaign.

ADVISOR - ADRIAN HONG



Founder and Director of The Pegasus Project, Co-founder and former Executive Director of Liberty in North Korea (LiNK). Mr. Hong is currently a visitor at Princeton

University's Center for Information Technology Policy. He has contributed to the *International Herald Tribune/New York Times*, the *Christian Science Monitor*, the *Washington Post* and the *Los Angeles Times*, and has briefed parliaments, ministries, diplomats and governments around the world. He also runs [Indy](#) Incubator, a small incubator for early stage non-profits and socially-conscious businesses. Indy Inc. helps groups avoid the pitfalls of early-stage organizations and sharpen their mission, business plan, structure and legal status. Mr. Hong was a Visiting Lecturer in 2008 teaching "America, Human Rights and Foreign Policy" at Korea's Ewha University, and was recently selected as an inaugural TED 2009 Fellow, a 2009 Arnold Wolfers Fellow at Yale University, and an inaugural [TED Senior Fellow](#). In 2009 he was selected to receive the the Japanese American Citizens League "Vision Award."

WEB ADMINISTRATOR - ELIFARLEY CRUZ

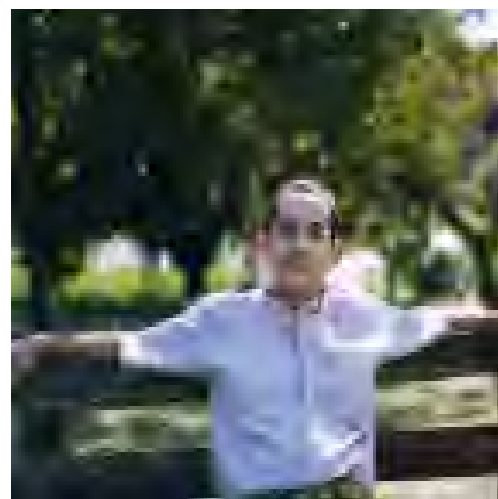

[Elifarley Cruz](#) is a software engineer from Brazil who has contributed to a number of open source software projects and to the [P2P Foundation](#) as

a co-editor. A long-time Linux user, he's passionate about open source software and hardware, knowledge sharing and the commons. He believes in the abolishment of artificial limitations and unrestricted sharing of knowledge as ways to bring forth the true human potential and take society to new heights. Mr. Cruz is helping OSE with IT issues, administration of the forum and wiki, and is a [True Fan](#).

BUSINESS CONSULTANT - LUIS DIAZ



With six years of progressive experience in formulation, implementation and execution of business and marketing strategies, Mr. Diaz actively participates in the organiza-

tional development and operations of OSE. As an advisor in strategic planning, he aids in ensuring that the organization's vision is properly implemented in accordance to its governance, bylaws and mission. Previously, Mr. Diaz was engaged in launching several new ventures and provided guidance in the areas of brand design and development, financial planning, internal management systems and human resources. 🍷

[Make a Comment](#) • [Email Link](#)
[Send Letter to Editor](#) • [Save Link](#)

[Audio Marcin Jakubowski Video on Declare Your Independence With Ernest Hancock - August 4th, 2011](#)

Global Village Construction Set

[Make a Comment](#) • [Email Link](#) • [Send Letter to Editor](#) • [Save Link](#)



THE **Global Village Construction Set (GVCS)** is an open technological platform that allows for the easy fabrication of the 50 different *Industrial Machines* that it takes to build a small civilization with modern comforts.

Key Features of the GVCS:

Open Source - Low-Cost - Modular - User-Serviceable - DIY - Closed-Loop Manufacturing - High Performance - Heirloom Design - Flexible Fabrication

A modern, comfortable lifestyle relies on a variety of efficient Industrial Machines. If you eat bread, you rely on an Agricultural Combine. If you live in a wood house, you rely on a Sawmill. Each of these machines relies on other machines in order for it to exist. If you distill this complex web of interdependent machines into a reproduceable, simple, closed-loop system, you get these:

The GVCS 50:

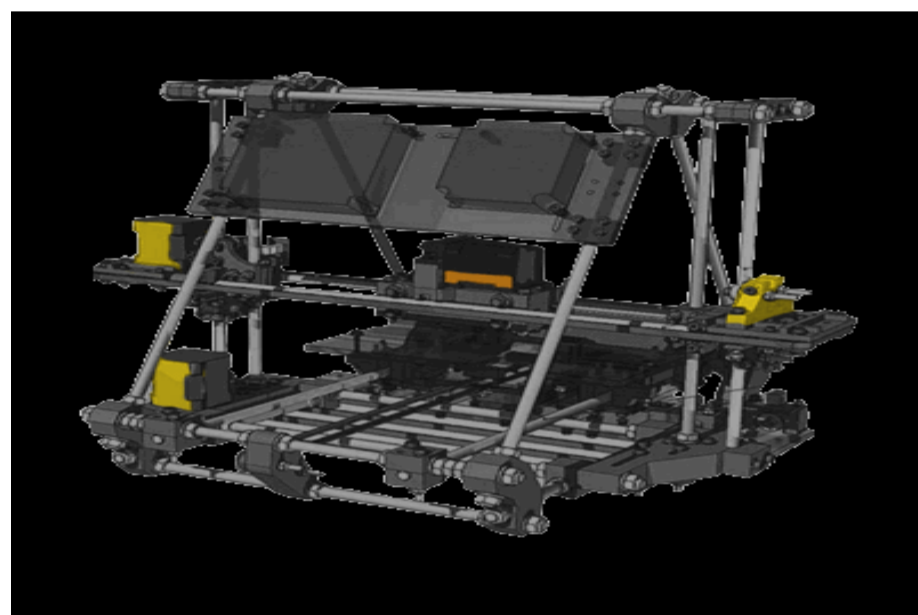

3d Printer

an additive manufacturing technology where a three dimensional object is printed by laying down successive layers of material, just like a printer except in 3D.



3d Scanner

a device that can generate a 3D digital scan from a real-life object, where the file can be used to reproduce the object in 3D with a device such as the 3D printer or CNC Precision Multimachine.



50 kW Wind Turbine

a device that produces electrical power from wind energy, scalable in units of 50 kW.



Aluminum Extractor from Clay

a device that produces aluminum from clay by dissolving the aluminum from aluminosilicate (clay), and then electrolyzing the resulting compound to form pure aluminum.



Backhoe

a piece of excavating equipment or digger consisting of a digging bucket on the end of a two-part articulated arm for digging trenches or large holes.



Bakery Oven

device for heating various forms of dough into breads and other baked goods.

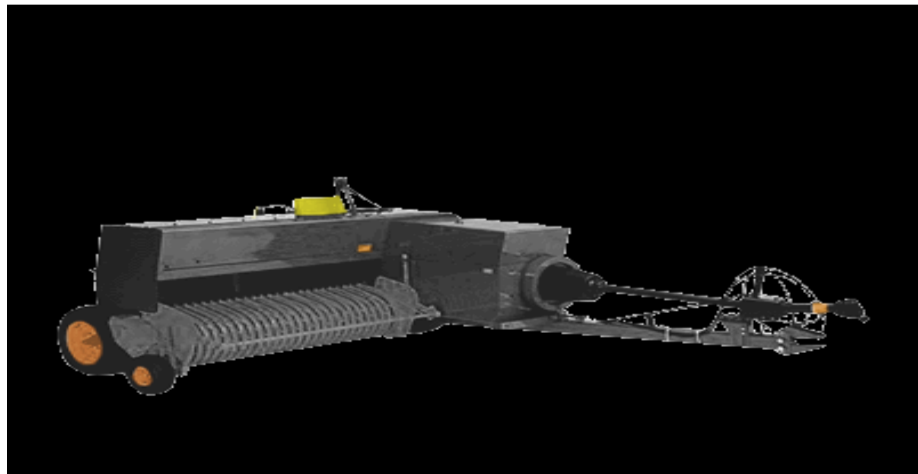

Baler

a device that compresses hay and other light and dispersed materials into more compact bales.

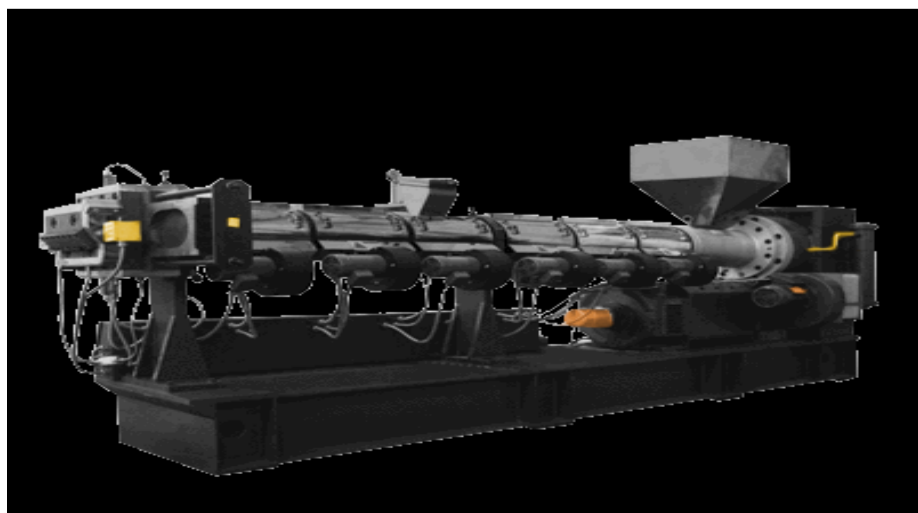

Bioplastic Extruder

An extruder takes a charge of plastic and extrudes a sheet or other profile of useful form, such as greenhouse glazing or water tubing.

Continues on Page 35

Continued from Page 34 - Global Village Construction Set



Bulldozer

a high-traction, heavy earth-moving machine indispensable for building ponds, berms, and other permacultural earthforms, as well as for other tasks such as building roads or clearing land.



CEB Press

a high performance machine for producing Compressed Earth Blocks (CEB) from onsite soil, at production rates of up to 16 bricks per minute.



Cement Mixer

a device that homogeneously combines cement, aggregate such as sand or gravel, and water to form concrete.



Chipper/Hammermill

a machine used for reducing wood or other materials into smaller parts, such as chips or shreds.



CNC Circuit Mill

a computer-controlled device that can produce electrical circuits by milling and drilling on copper-clad circuit boards.

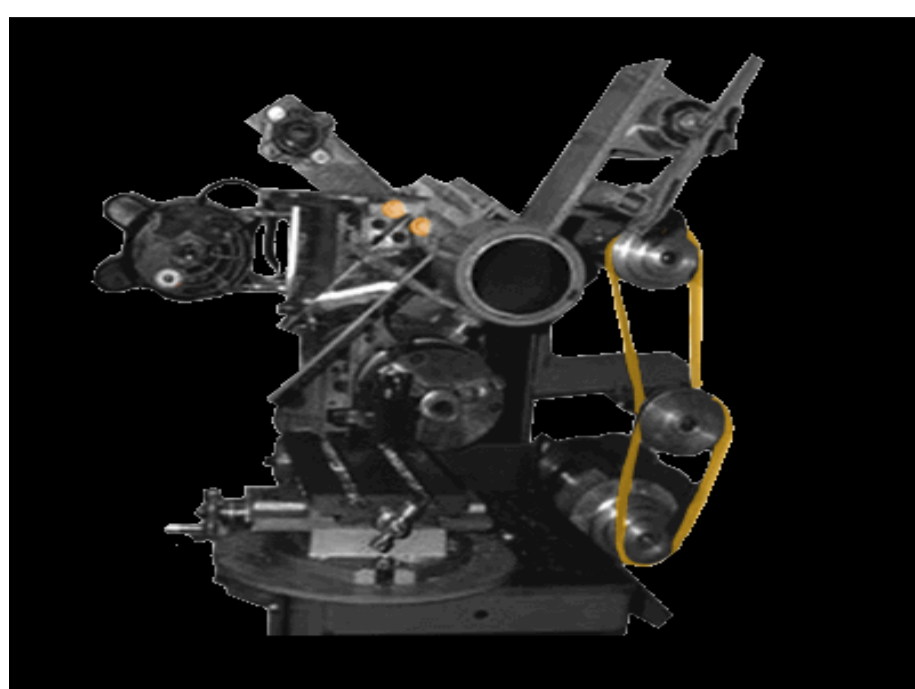

CNC Precision Multimachine

a multipurpose, precision CNC machining and metal cutting device for milling, lathing, drilling to make precision parts; includes surface grinding and cold-cut metal sawing.



CNC Torch/Router Table

a computer-controlled cutting table for metal where a moving torch head is used to produce precision metal parts in a fraction of the time that it takes to do so manually .



Dairy Milker

device which harvests milk automatically from milk-producing livestock.

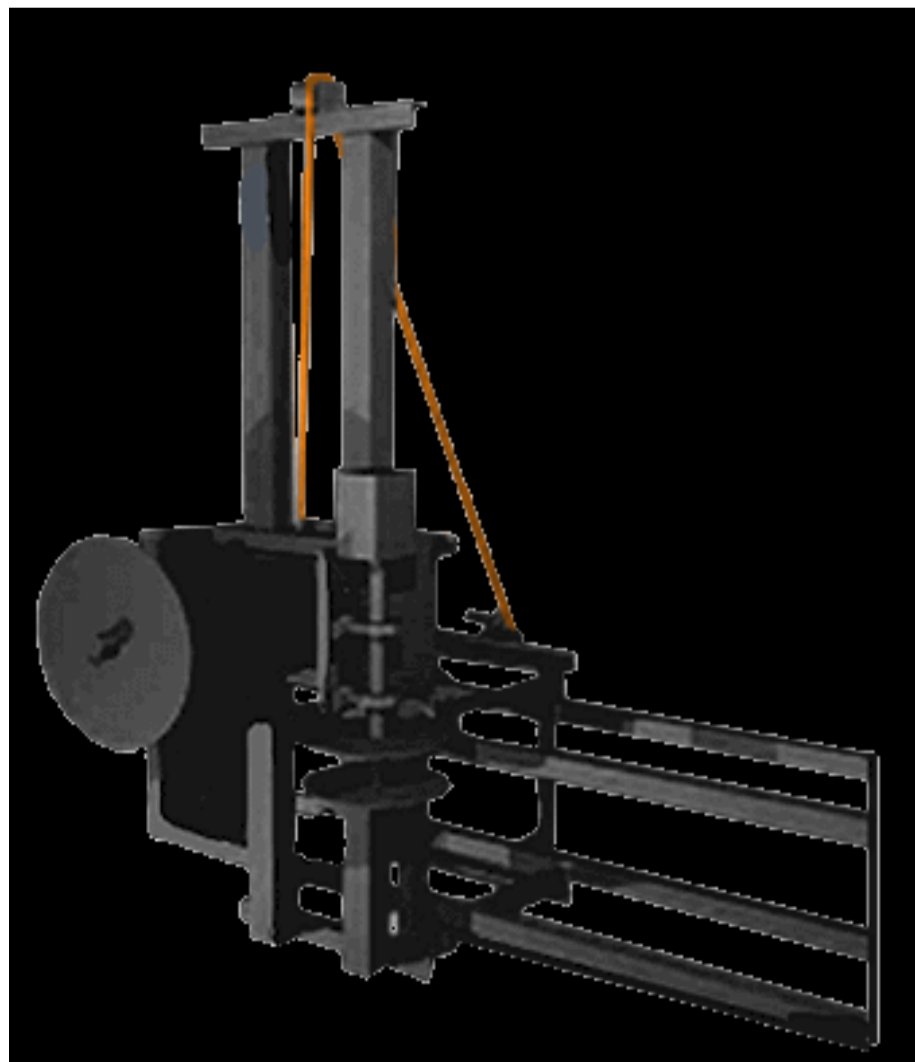

Dimensional Sawmill

a dimensional sawmill is a circular blade sawmill with 2 blades that is used for producing dimensional lumber in one pass.

Continues on Page 36

Continued from Page 35 - Global Village Construction Set

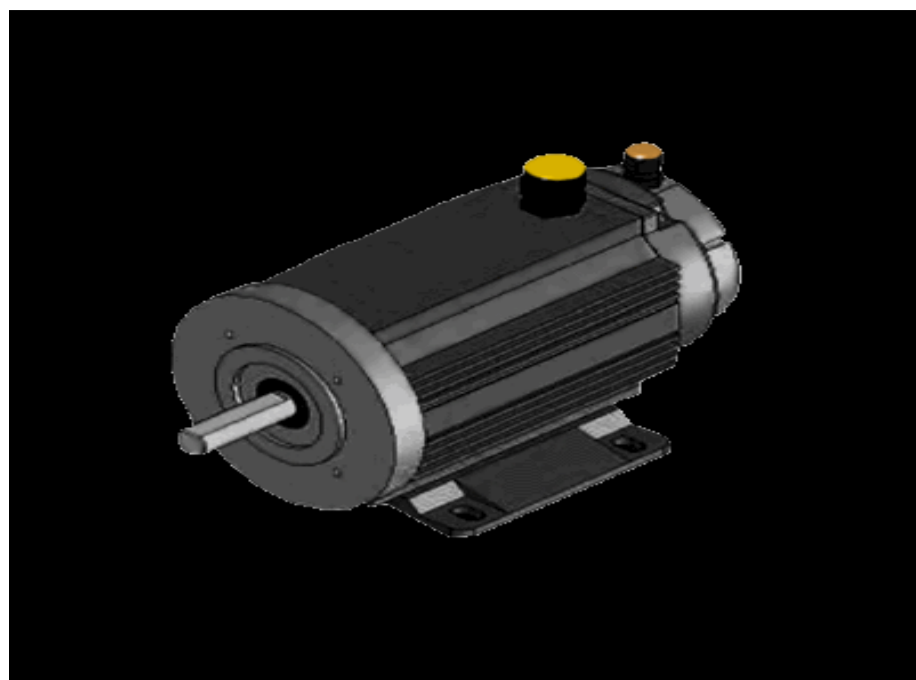

Electric Motor/Generator

a device that functions as a motor when energized with a voltage, which can also function as an electrical generator when it is spun.

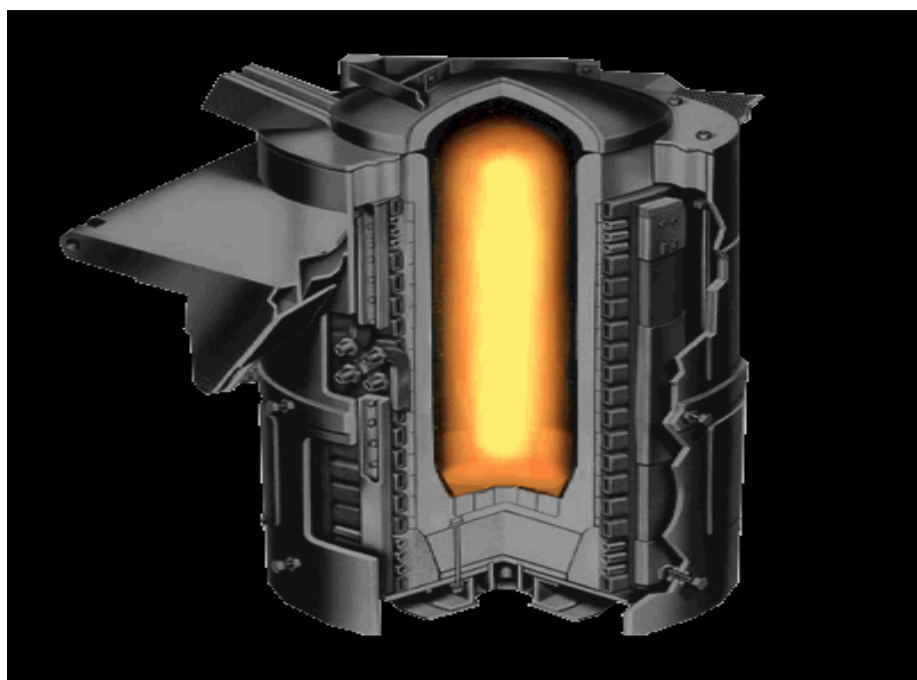

Induction Furnace

an electrical furnace in which the heat is applied by induction heating of metal, providing clean, versatile, compact, energy-efficient, and well-controlled melting compared to flame furnaces.

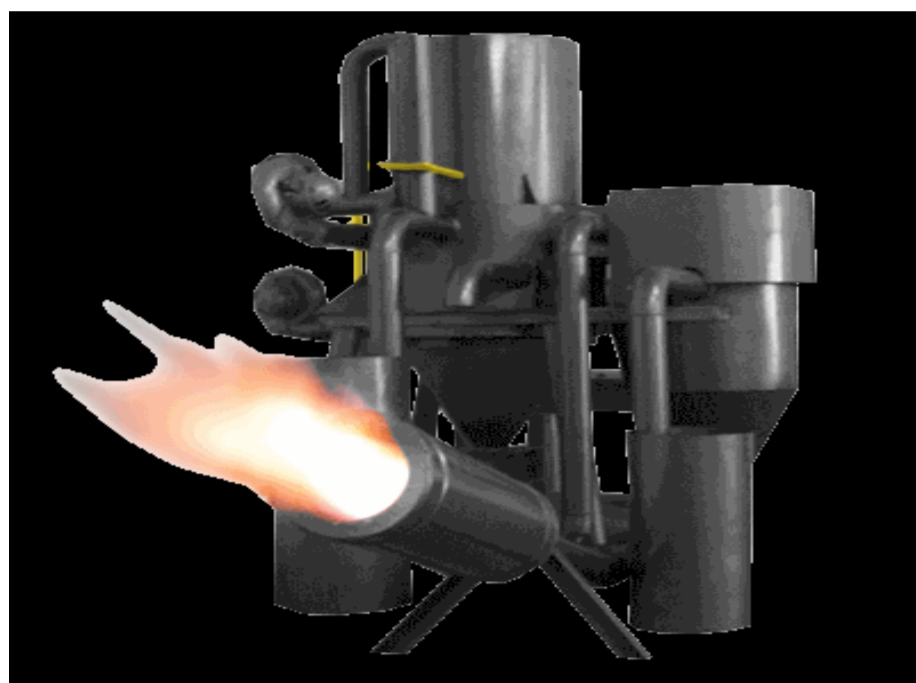

Gasifier Burner

a clean and efficient burner that gasifies the material that is being burned prior to combustion.



Industrial Robot

a robotic arm which can perform certain human tasks – such as welding or milling – for performing tasks that are not better done by humans.

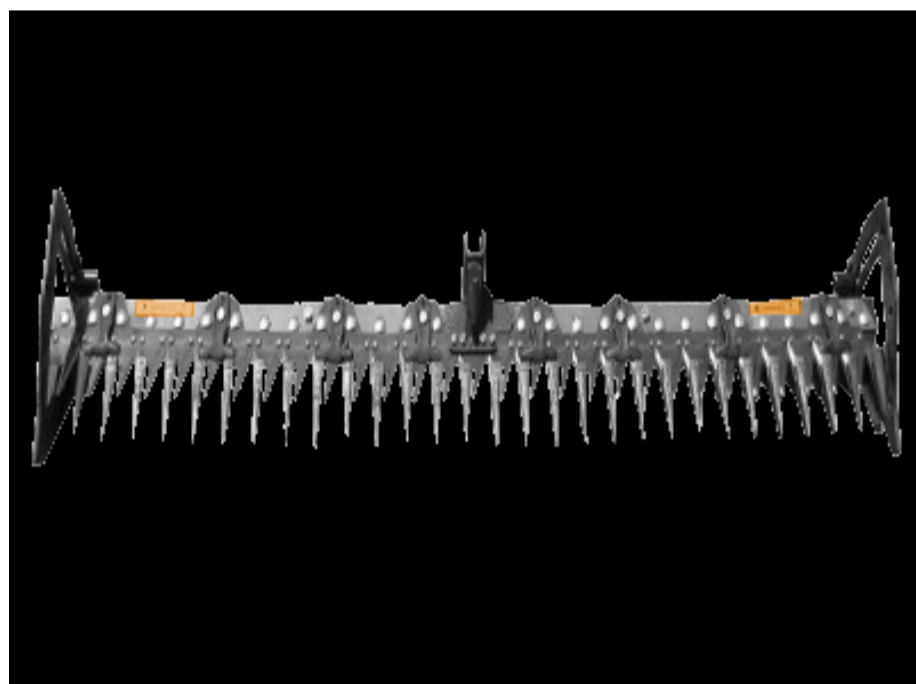

Hay Cutter

a device that cuts grass, hay, straw, or other light biomass for haying, baling, or combining.



Ironworker Machine

a device that can instantly cut steel and punch holes in metal thicknesses of 1”.



Hay Rake

a mechanical implement for a tractor that rakes hay or other light materials into windrows or other formations for drying or baling.

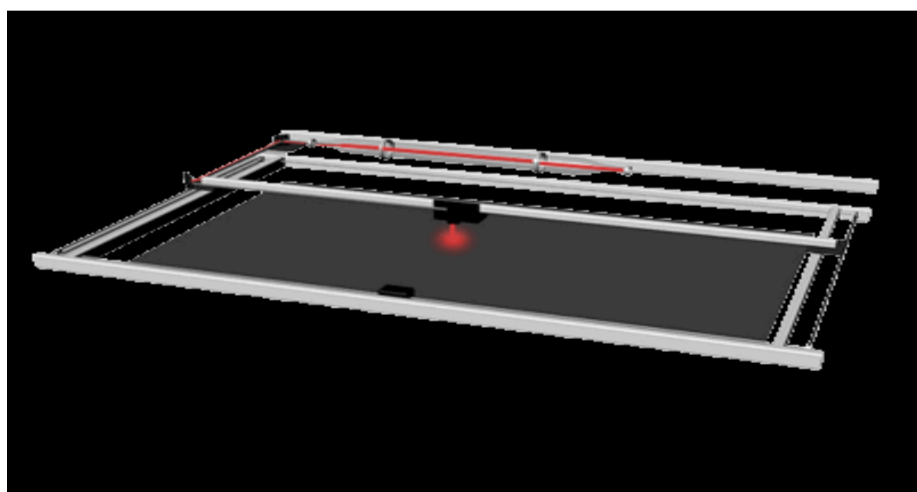

Laser Cutter

an industrial machine that can make precision, finish cuts in a wide array of substrates, such as metal, wood, or plastic.

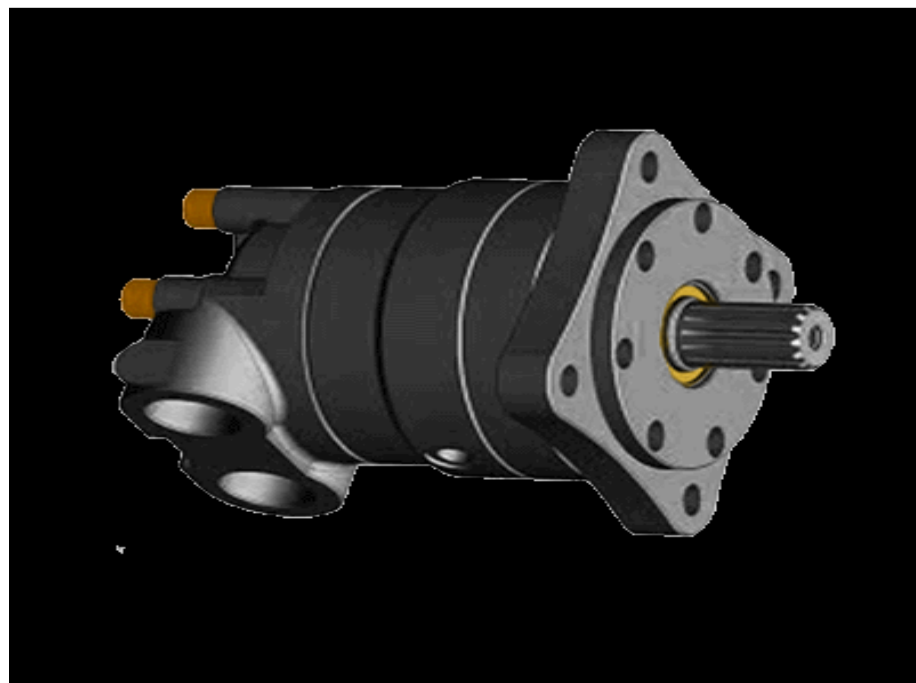

Hydraulic Motors

a mechanical actuator that converts high-pressure fluid flow into rotation.



Linear Solar Concentrator

an infinitely-scalable, linear device which concentrates solar radiation onto a linear target for generating heat or steam to produce electricity.

Continues on Page 37

Continued from Page 36 - Global Village Construction Set

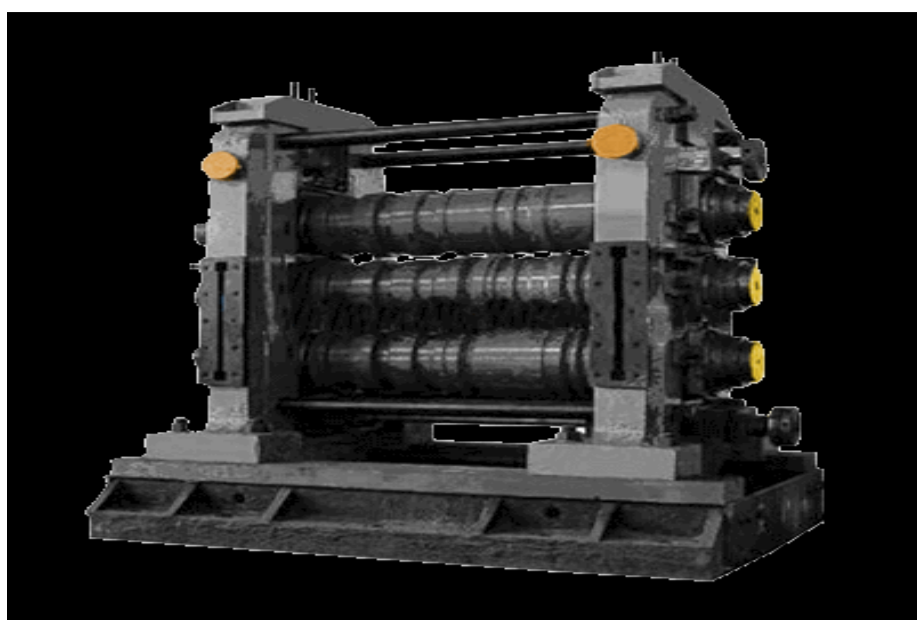

Metal Rolling

a metal forming process in which metal stock is passed through a pair of rolls to produce a desired shape, such as flat bar, angle, or u-channel.



Open Source Automobile

a wheeled motor vehicle for transporting people.



Microcombine

a small-scale harvester-thresher for mechanical harvesting of any grain crops, with a cutting swath of about 3 feet in width.



Open Source Truck

a larger version of an automobile with a bed for transporting loads.



Microtractor

a small, 18 hp version of the full-sized tractor for powering a wide range of implements in agriculture and utility duties.



Open Source Welder

a device used to make strong, permanent bonds in metal by melting and fusing the metal.

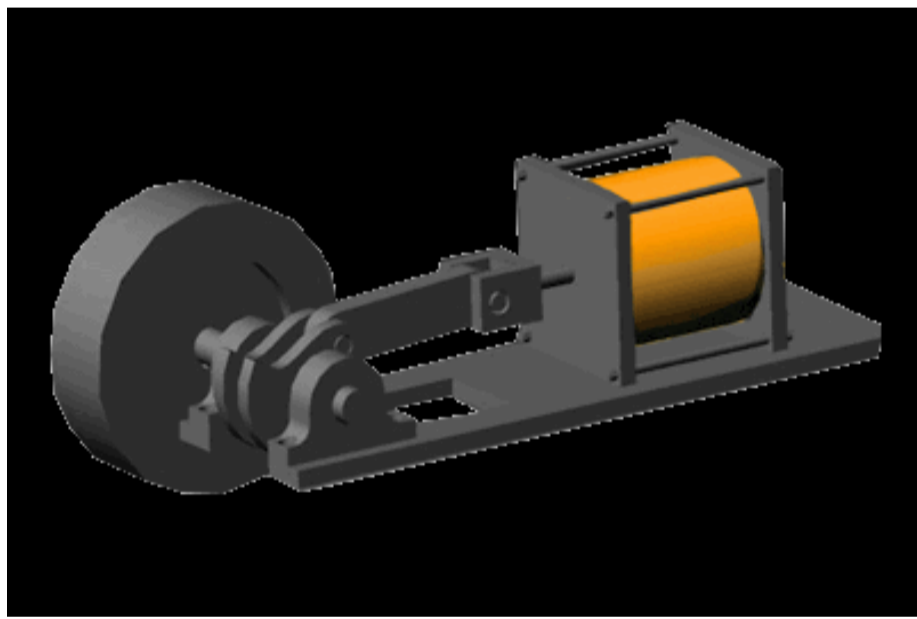

Modern Steam Engine

an engine where an external heat source is used to turn water into steam, and the steam in turn moves reciprocating pistons to provide shaft power.



Pelletizer

a device that compresses shredded pieces of biomass or other substances to compact, flowable pellets.



Nickel Iron Batteries

long-life batteries that have a track record of lasting 50 or more years.



Plasma Cutter

a device to cut metal using a plasma torch.

Continues on Page 38

Continued from Page 37 - Global Village Construction Set

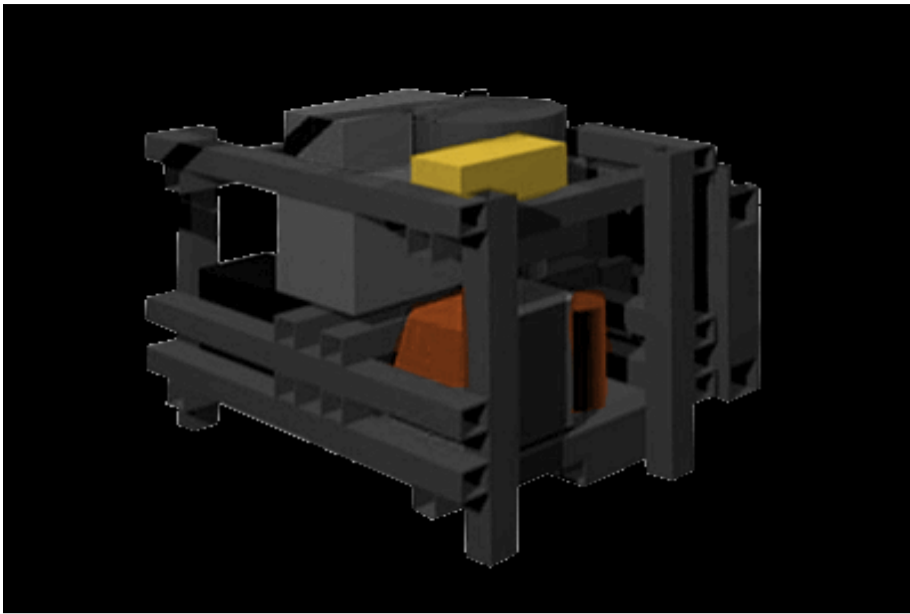

Power Cube

a multipurpose, self-contained, hydraulic power unit that consists of an engine coupled to a hydraulic pump.

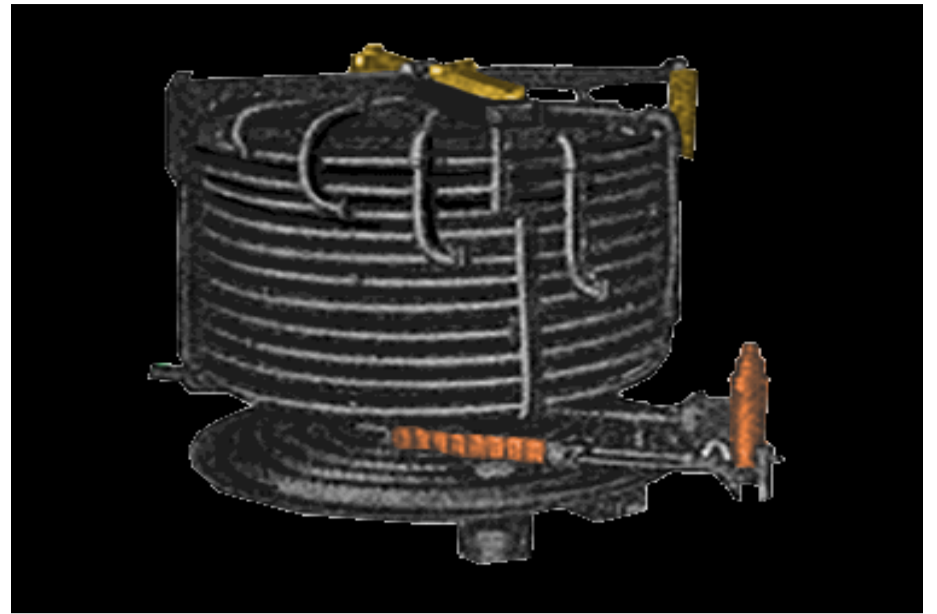

Steam Generator

a device that generates steam from water that is passed through externally-heated coils.

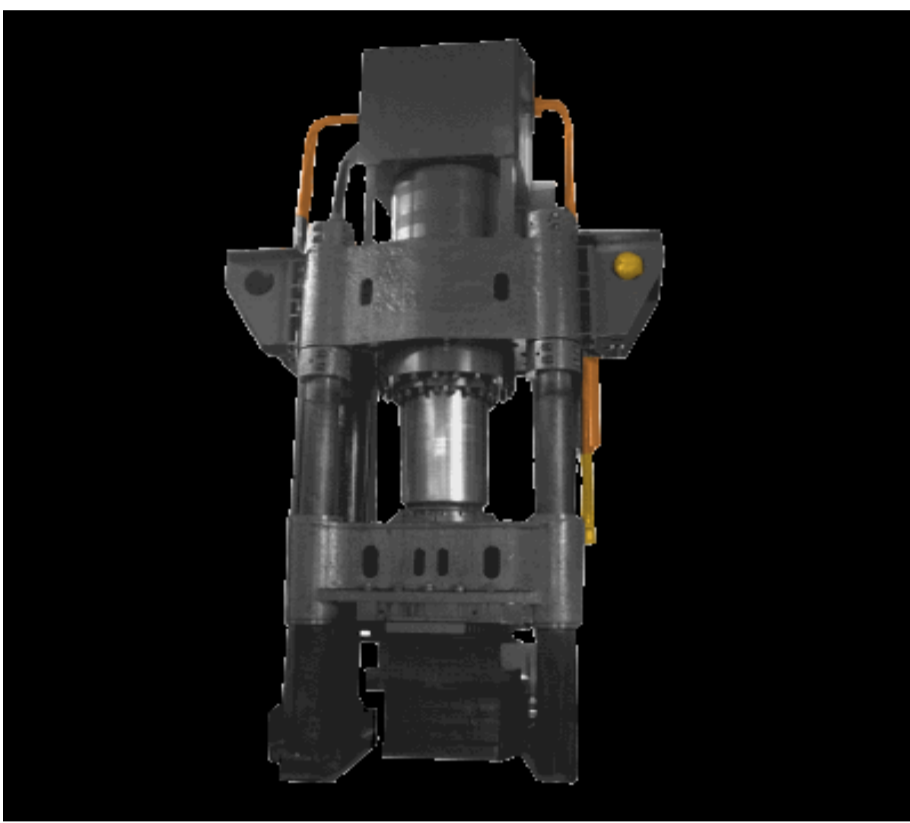

Press Forge

a device for shaping metal by the application of a shaping die and a continuous pressure or force.



Tractor

a versatile, 4-wheel drive, hydraulically-driven, skid-steering tractor with 18 to 200 horsepower capacity for agriculture, construction and other utility duties.

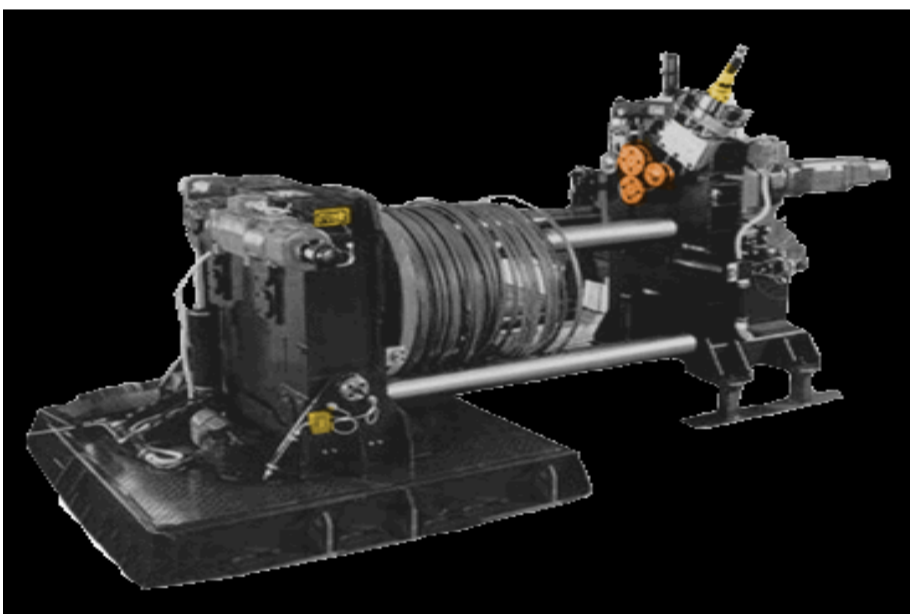

Rod and Wire Mill

a subset of metal rolling, used to make shafts, rebar, thin rods, and down to wire.



Trencher

a piece of construction equipment that uses a cutting wheel for digging trenches, laying pipe, cable, or drainage.



Rototiller and Soil Pulverizer

a tractor implement that tills soil with blades via rotary action.



Universal Power Supply (UPS)

This is a combination power supply for applications from off-grid power to supplying power to welders, induction furnaces, and plasma cutters.



Spader

a set of mechanical shovels that prepare soil for planting without causing a hardpan typical of rototiller tilling.



Universal Rotor

a tractor-mounted rotor that can be fitted with a wide array of toolheads, such as string trimmer, posthole digger, tree planting auger, slurry mixer, and many others.

Continues on Page 39

Continued from Page 38 - Global Village Construction Set



Universal Seeder

a tractor-pulled seeder that can plant any seed, from small seeds like clover to large seeds such as potatoes.



Well-Drilling Rig

a device for digging deep water wells.

Global Village Construction Set in 2 Minutes



Open Source Ecology



[Make a Comment](#) • [Email Link](#) • [Send Letter to Editor](#) • [Save Link](#)

The Three Cornerstones of UN Agenda 21/Sustainable Development are Economy, Ecology, and Social Equity.

By Rosa Koire

[Make a Comment](#) • [Email Link](#) • [Send Letter to Editor](#) • [Save Link](#)



ECONOMIC collapse creates a chain of events, but on a micro level (county, city) there is a marked reduction in revenue for maintenance of services. Loss of services to outlying areas means, for example, roads not being maintained to rural and suburban areas. Roads not being maintained to those areas, schools not being supported in those areas, law enforcement/fire/social services not being supported in those areas means a gradual movement into the denser city centers. Add to that the increased cost of gasoline (manipulated), and the higher cost of energy (manipulated) to heat and cool statistically larger homes, and you have more pressure to leave rural and suburban areas. Reduction of energy usage is key. Smart Growth/New Urbanism in Redevelopment Areas is the supposed answer: smaller units, attached condos, little or no parking, few private cars. More eyes on the street. Redevelopment projects are the implementation arm of the UN plan, and include rezoning of huge sections of your cities to Smart Growth zones. This physical manifestation of UN Agenda 21 is social engineering paid for with your property tax dollars. These areas then have their property taxes diverted away from your services and into the pockets of a few developers and bond brokers for 30-45 years. Result? Bankrupt cities and counties.

In addition to these factors, ecologically motivated regulation makes rural/suburban development prohibitive. From stream/creek/ditch protection to watershed protection, to bayland/inland/rural corridor prohibitions, to increased species protection (lists are growing), the use of land is greatly limited. Water well monitoring and loss of water rights reduce the opportunity for living outside of cities. Wildlands programs that prohibit roads and trails into rural areas while supposedly protecting them with conservation easements increase the loss of our food source independence. The sale of development rights to Agricultural Land Trusts that restrict farmers and ranchers from using their lands and therefore make it impossible to farm for more than one more generation endanger our ability to feed ourselves.

Add to this the pressure from ICLEI Climate Protection Campaigns to reduce our energy usage to pre-1985 levels, and increased regulations on industry and you have the perfect storm for loss of jobs and greater dependence on other countries for goods. As the population becomes more and more urbanized and less able to provide food or necessary products, more people are dependent on the government for housing, food, and other basic necessities. Government itself becomes dependent on grants and loans with requirements attached. In this way policy-makers are influenced and pressured by the corporatocracy. Public/private partnerships favor some businesses over others and completely

unbalance the playing field. Independent businesses go bankrupt. Poverty works its way into the middle class.

Social equity, another one of the cornerstones of Agenda 21 comes in here. As a major leveler, the loss of money, land, food, and energy independence brings the US into 'social equity' with the poorer countries. This is a goal of Agenda 21. Health will suffer, presumably health care will suffer, nutrition will suffer. Psychological problems, stress from living in tight Smart Growth areas with other un- or underemployed people, and crime will result. Community Oriented Policing will encourage, if not require, people to watch their neighbors and report suspicious activity. More activity will be identified as 'crime'--such as obesity, smoking, drinking when you have a drinking problem, name calling, leaving lights on, neglect (in someone's perception) of children, elderly, and pets, driving when you could ride a bike, breaking a curfew, and failure to do mandatory volunteering. The 'community' will demand more law enforcement to restore order, and more rules and regulations will ensue. The lines between government and non-governmental groups will blur more and more as unelected local groups make policy decisions using the Delphi Technique to manufacture consensus. The Chinese and Russian models are instructive in what you can expect under Communitarianism. See Nien Cheng's *Life and Death in Shanghai*, and Alexander Solzhenitsen's *The Gulag Archipelago* for real world examples. The war on terror is a Communitarian plan designed to terrorize YOU.

You can see that the groundwork for this has been laid and is being implemented throughout the nation. When you create deep dependence and then withdraw assistance the result is chaos and poverty. Propaganda infuses our culture with messages that there are just a few winners and many losers; that we are killing the earth and time is running out; that prosperity is an anachronism and detrimental to life; that individual freedom is selfish and injures those who are less free.

This is UN Agenda 21/Sustainable Development.

Communitarianism is the 'balancing' or subsuming of individual rights below the needs of the 'community.' The community is defined now as the global village. So anything identified as serving the global village takes precedence over the rights of the individual. In the United States, our constitution guarantees our rights to life and liberty. Ownership of property includes that of our own persons.

Personal liberty is at odds with Communitarianism, the new standard of the Twenty-first Century. Join us in fighting UN Agenda 21/Sustainable Development.

[The Post Sustainability Institute](#) 

[Make a Comment](#) • [Email Link](#)
[Send Letter to Editor](#) • [Save Link](#)

"AGENDA 21"

The United Nations Plan For Global Control

A Presentation by
ROSA KOIRE, ASA
 Executive Director
 Post Sustainability Institute



Unlimited Debt

By William Buppert

[Make a Comment](#) • [Email Link](#) • [Send Letter to Editor](#) • [Save Link](#)



“GIVING money and power to government is like giving whiskey and car keys to teenage boys.”
 - P. J. O'Rourke

The alleged debt crisis is at the top of the news now. The usual suspects in Mor-dor on the Potomac are proclaiming that if they do not leverage the unborn into further debt they will be unable to fulfill their fiscal and fiduciary obligations to a wide variety of parasites and looters at the government trough ranging from pensioners to killer robots.

I would submit to you that there should be no limit on the government's debt ceiling. None. It should be unlimited. It is illusion and misdirection to think that any entity which can simply force assets and wealth from a captive population would think these limitations important except as a good, if insincere, public relations campaign with the host they are draining. Within the next six months, these united States will achieve a signal triumph: an alleged national debt that is equal to the established consensus on the amount of the GDP. We are presently at 95 percent of that goal and rising. Russia is at 19 percent and China is at 11 percent. Even communist countries know better. Mind you, I didn't mean to besmirch the communist idea in front of the chattering classes as they may find that disturbing since that is their [philosophical touchstone](#) for economic prosperity. Much like a demonic telethon to enslave young and unborn generations to enormous debt obligations, the good ship USS Leviathan continues to happily navigate toward these dangerous fiscal shoal waters. I say alleged debt because we are all certain the government cooks the books and hides spending it wishes not to reveal, therefore future financial historians may discover evidence of the real debt as they poke and prod the ruins of a former global hyper-power in North America.

Non-funded obligations approaching anywhere from 60-115 trillion dollars loom in the future as the demographic tsunami of pending entitlements crashes on the shores of the Potomac. Some estimate this as high as [202 trillion dollars](#). A slight grasp may be entertained by realizing that there are two trillion seconds in 64,000 years. In reality, this bespeaks one devilish conclusion: not only is the Federal government NOT too big to fail but it should have failed decades ago. What the usual suspects and

the punditocracy fail to grasp is that the government has reached such gargantuan and unmanageable proportions, its failure is inevitable. The entropy of imperfect information used on such a large scale and steered by the kakocracy that is the American political class and the shambling bureaucratic masses employed by the State will end in history's largest collectivist car crash.

Even if they were to tax the productive classes who make [250,000 dollars per annum](#) or more 100 percent, they would be hard-pressed to fund the budget for four to six months. [FDR](#) even toyed with the idea of a 100 percent tax rate in 1943 but finally settled on the paltry figure of 94 percent. You will note this is a little over a million souls. Also keep in mind that this tremendous debt is not being used to fund expensive tooling and plants for viable enterprises which would generate profit yield in innovation and production. No, these wealth transfers mostly end up both literally and figuratively in the septic tank.

Other commentators have covered more than [sufficiently](#) and with aplomb the manifest reasons why an increase in the debt is wrong and why by extension the entire fiscal apparatus is wrong. I agree with them. But, in the end, the State's very existence is wrong and they are simply using thimbles to bail the Titanic after the fatal collision.

My keenest desire is for the US Federal government to spend with abandon, print as if there is no tomorrow (they are prophetic, aren't they?) and produce a state leviathan so large and cumbersome that Lenin would be chagrined at the excess.

There is no such thing as a courageous politician because they are self-selected strata of psychopath whose prime directive is preservation and expansion of power at everyone's expense except their own. Any expectation otherwise will always result in severe disappointment on your part. It is ironic that the worst elements of humanity are those in charge but history is rife with such folly.

This time I want Obama to win and to continue to print and spend as if there is no tomorrow. My prognosis is fiscal collapse and the future is bright. Wait for it...

“Ancient Rome declined because it had a Senate, now what's going to happen to us with both a House and a Senate?”
 - Will Rogers 

[Make a Comment](#) • [Email Link](#)
[Send Letter to Editor](#) • [Save Link](#)

[The Scientific Dictatorship Explained](#)

By Daniel Taylor

[Make a Comment](#) • [Email Link](#) • [Send Letter to Editor](#) • [Save Link](#)



PRESIDENT Dwight D. Eisenhower's legendary farewell speech is often cited in condemnation of the Military Industrial Complex, which is intimately connected to the subject at hand. However, there is another little discussed yet vital topic in the latter half of his speech. "The prospect of domination of the nation's scholars by Federal employment, project allocations, and the power of money is ever present and is gravely to be regarded," warned Eisenhower. "Yet, in holding scientific research and discovery in respect, as we should, **we must also be alert to the equal and opposite danger that public policy could itself become the captive of a scientific technological elite.**"

Who Are "They"?

I firmly believe that in the absence of historical background and full spectrum context, present day and future issues cannot be fully understood. This report will attempt to clarify the essence of the term "Scientific Dictatorship" by providing historical context and stories of the individuals involved in its modern manifestation.

The ideological roots of the Scientific Dictatorship can be traced to the works of Plato some 2,000 years ago. In truth, humanity has been battling the formation of this tyranny for much of known history. The formation of the United States Constitution created a barrier that [H. G. Wells wrote](#) in 1901, had "...to be modified or shelved at some stage..." The focus here is on the modern forms of scientific power that began in the 20th Century and are blossoming in the 21st Century. The Scientific Dictatorship is composed of unelected individuals that have access to the reigns of power. These individuals have access to undisclosed future technology, classified intelligence, and the ability to steer scientific research that impacts our entire society.

The works of [Bertrand Russel](#), Julian Huxley, Aldous Huxley, [Charles Galton Darwin](#), [H.G. Wells](#) and many others provide the mental framework from which this modern tyranny is based upon. The following are several examples of men who helped form the Scientific Dictatorship of the 21st Century. For readers who are new to this information, what you see here is a small portion of the full kaleidoscope of information available. This will give you a start for any in-depth research that you should decide to do.

Vannevar Bush: First Science Advisor, Founder of Raytheon

Born in 1890, Vannevar Bush would become the first Science Advisor to the United States government during World War II under President Franklin Roosevelt. Bush played a vital role in the creation of what we know today as the Military Industrial Complex. Specifically, the method of scientific research of this gargantuan organization – beginning with the Office of Scientific Research and Development – was devised by Vannevar.

The roots of the internet can be traced to Bush's ideas in 1945. The forerunner to the computer itself can also be attributed to his early designs. With the help of the large foundations, Vannevar Bush pioneered [many of the modern instruments](#) of the Scientific Dictatorship. Bush's

most notable accomplishment was serving as the organizer of the Manhattan Project which produced the Atomic bomb.



Bush's work with the Manhattan Project helped to cement the centralization of scientific research under the U.S. Military. This combine of research and development has since then developed into a network of contractors and various agencies. One of the world's largest defense contractors of today is the Raytheon Company, founded by Vannevar in 1922. Much of the technology that is initially developed by the military is inevitably released into society.

One such example is the internet. Vannevar Bush's initial ideas are considered to be the ideological roots of the internet. In a 1945 paper titled "As We May Think" Bush writes on his "memex" concept,

"The owner of the memex, let us say, is interested in the origin and properties of the bow and arrow. He has dozens of possibly pertinent books and articles in his memex. First he runs through an encyclopedia, finds an interesting but sketchy article, leaves it projected on his screen... Occasionally he inserts a comment of his own, either linking it into the main trail or joining it by a side trail to a particular item... Thus he builds a trail of his interest through the maze of materials available to him."

DARPA would eventually develop the internet and bring it to reality. While the internet is being used today as an [unprecedented tool for surveillance](#), it is at the same time serving as an unmatched medium for activism.

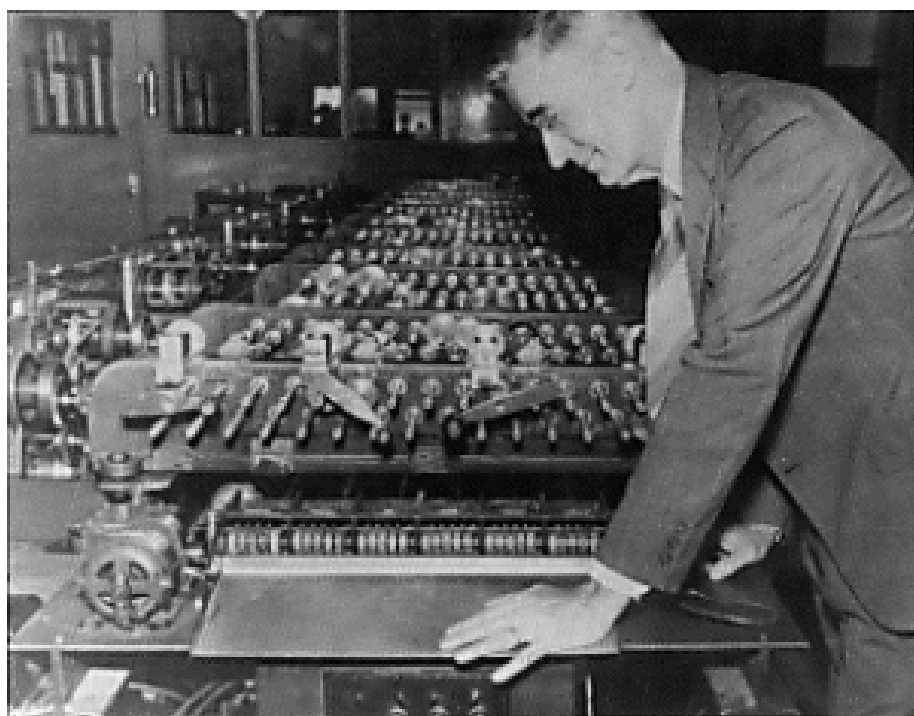

Bush with his mechanical differential analyzer

From 1935 to 1946 the Rockefeller Foundation [funded Vannevar Bush's development](#) of the [mechanical differential analyzer](#) at MIT for a total of \$230,500. This device, along with the Hollerith machine, is considered to be one of the forerunners of the desktop computer that we all know and use today.

Bush also served as president of the Carnegie Institution from 1939 to 1955, where he helped shift the organization's focus away from old-style eugenics to population control. In [A social history of anthropology in the United States](#), Thomas Carl Patterson writes that as President, "...Vannevar... ended its support for Daven-

Continues on Page 43

Continued from Page 42 - The Scientific Dictatorship Explained

port's projects [The Eugenics Records Office]. The eugenics movement was transformed with Rockefeller support as its focus shifted from heredity to population control and to birth-control experiments on an international scale."

As G. Pascal Zachary documents in his book *Endless Frontier*, Bush gave lip service to the importance of the individual, but he was an advocate of [a type of technocracy](#) in which society is ruled "...by the well-to-do and highly educated." He also saw "...populism and the widening participation of citizens in the machinery of government as a recipe for decline." Zachary comments that "Bush's fear of the 'blind mass' was widely shared in his circle of senior scientists and engineers." Also documented in *Endless Frontier*,

"As the years went on, the prevailing respect for experts emboldened Bush to advocate technocracy even more unabashedly. In the mid 1950s, he made headlines by calling for a "natural aristocracy" that would govern "the climate of opinion" in the country out of which politics and values arise."

Much of what Vannevar Bush set in motion led directly to the explosion of technological advancement that we are witnessing today. While technology itself is neutral, the elites that are directing its development are doing so with specific agendas in mind, and we are not being asked to debate it.

Herman Kahn: Father of Scenario Planning

"Herman Kahn has been a major figure in one of the most fascinating shifts of power in U.S. History: from identifiable public leaders to the 'action intellectuals.'" – *Life Magazine*, December 6, 1968

Herman Kahn is known as one of the founding fathers of future studies. After working for the RAND Corporation, Kahn founded the Hudson Institute in 1961. The satirical film *Dr. Strangelove* is largely based on real documents and ideas that came from RAND. The December 6, 1968 [edition of Life Magazine](#) details Kahn's career, and the larger implications of an unprecedented shift of power to unelected "action intellectuals." As Life Magazine reports,

"...Herman Kahn has been a major figure in one of the most fascinating shifts of power in U.S. History: from identifiable public leaders to the 'action intellectuals.' As counselors to the decision-makers, men such as Kahn often have access to future technology (what is known, but not yet disclosed) and official intelligence (what is known, but not yet revealed, about the capacities and plans of other nations).

Thus, decisions – based on private knowledge, analyzed by private consultants and debated in private – can become public policy. This is a process of invisible power. At its extreme this influence can commit a nation to social programs and military actions which have neither been fully explained nor publicly debated. One day, as that power pervades and grows more sophisticated, it may so affect the course of government that any nation's policies may be locked in, as if by automatic pilot, years before the men who are elected to govern ever take office."

This process of invisible power is further enabled by the annual secret gatherings of the Bilderberg Group – founded in 1954 – which consist of international bankers, CEO's of major tech corporations, editors of major news outlets, and other power brokers.

An historical example of this process in action is the formation of the European Union's common market, [which was developed](#) behind closed doors at a 1955 Bilderberg conference in Germany.

Ivy Lee and Edward Bernays: Modern public relations and perception management

Ivy Lee is considered to be the first public relations man. Lee was hired by John D. Rockefeller Jr. to recast the family's image after the infamous Ludlow massacre. A more widely recognized figure in PR is Edward L. Bernays, the nephew of Sigmund Freud, who helped to significantly advance the study of propaganda into the 20th Century.

In his 1928 book *Propaganda*, Bernays informs readers about the true ruling class in our society.

"The conscious and intelligent manipulation of the organized habits and opinions of the masses is an important element in democratic society. Those who manipulate this unseen mechanism of society constitute an invisible government which is the true ruling power of our country.

We are governed, our minds are molded, our tastes formed, our ideas suggested, largely by men we have never heard of."

In 1953 Bernays aided the United States government in its overthrow of Guatemala. As Mark Crispin Miller notes in the introduction of *Propaganda*, "Bernays was... employed by the United Fruit Company, at whose behest the Eisenhower administration used the CIA to overthrow the democratically elected government of Jacobo Arbenz."

This clip from the documentary *Century of the Self* details the incident:



Water Fluoridation was also sold to America with the help of Bernays. As detailed in *The Fluoride Deception*, Christopher Bryson explains Bernays' connection with the National Institute of Dental Research.



The study of the mind of man has enabled advanced forms of subtle influence, of "manufacturing consent." The U.S. Army War College noted in 1998 that the "[Mind has no firewall](#)," and that "We are on the threshold of an era in which these data processors of the human body may be manipulated or debilitated."

Continues on Page 44

Continued from Page 43 - The Scientific Dictatorship Explained

Much of the Scientific Dictatorship's agenda would stop dead in its tracks in response to the simple act of the people becoming aware that there are attempts to manipulate our minds.

How does the Scientific Dictatorship operate?

Eisenhower's warning is especially prescient here. "The prospect of domination of the nation's scholars by Federal employment, project allocations, and the power of money is ever present and is gravely to be regarded," he warned. Tax-exempt foundations have played a critical role in directing society and technological development. For example, as president of the Carnegie Institution, Vannevar Bush "...was able to influence research in the U.S. towards military objectives and could informally advise the government on scientific matters."

As Dr. Lily E. Kay has documented in her book *The Molecular Vision of Life: Caltech, the Rockefeller Foundation, and the Rise of the New Biology*, large foundations effectively set in motion the entire scientific technological agenda for the 20th Century. Under the "Science of Man" agenda, the physical makeup of human beings was studied, and methods to alter various biological processes were devised. This inertia rippled throughout society and impacted the minds of the intelligentsia that were totally unconnected to the core group responsible for organizing the central project.

The Scientific Dictatorship often operates under the cover of darkness, under national security, private contractors, and deep levels of government secrecy.

One area of operations for this group is in bio weapons laboratories across the globe. [As revealed by The Age](#), Nobel prize winning Australian microbiologist Sir Macfarlane Burnet secretly urged the Australian government in 1947 to develop bio weapons for use against the "overpopulated countries of South-East Asia." In a 1947 meeting with the New Weapons and Equipment Development Committee, the group recommended that "the possibilities of an attack on the food supplies of S-E Asia and Indonesia using B.W. agents should be considered by a small study group."

The anthrax attacks that occurred shortly after 9/11 have exposed the underbelly of this system, [along with the murder](#) of Dr. David Kelly in 2003. Investigative journalist and film maker Bob Coen examined the anthrax case and concluded that an "international biological weapons mafia" is operating in total secrecy.



How can such a vast project go seemingly unnoticed? Why don't I know about this?

The professional classes of society have largely been schooled and specialized to a degree that limits their perspective on the full spectrum view of society; That is, until they are "brought into the fold." This is not by accident or happenstance. Just as Vannevar Bush desired rule by the "...well-to-do and highly educated," Bertrand Russel, in his 1954 book *The Scientific Outlook* writes,

"...the scientific rulers will provide one kind of education for ordinary men and women, and another for those who are to become holders of scientific power. Ordinary men and women will be expected to be docile, industrious, punctual, thoughtless, and contented."

To a great extent we are facing an *open conspiracy*, which H. G. Wells aptly named one of his many books. Herein lies one of our greatest challenges. We are not facing a clear and present danger that would normally trigger natural human instinct to fight back. It is a creeping death that is [subtly eroding](#) the human species. 🍂

[Make a Comment](#) • [Email Link](#)
[Send Letter to Editor](#) • [Save Link](#)

Agenda 21 in New York State - Home Rule and Article X

By: SARTRE – July 10, 2011

[Make a Comment](#) • [Email Link](#) • [Send Letter to Editor](#) • [Save Link](#)



NUMEROUS critics condemn the insidious nature of Agenda 21. Usually the arguments are based upon the intrusion of the United Nations to mismanage the planet and reduce people to a sinister petri dish experiment. Their reach and methods

used by this octopus that is strangling the globe, include specific actions that force their agenda down the throats of government entities. The recent passage of Article X in New York State illustrates a direct assault on the treasured principle of Home Rule. Connecting the dots and tying the links together forecast a grim reality that is ready to explode into a vicious turf fight.

The United Nations publication for [Sustainable Development](#) describes their objectives and announcements.

Agenda 21 is a comprehensive plan of action to be taken globally, nationally and locally by organizations of the United Nations System, Governments, and Major Groups in every area in which humans impact on the environment.

Agenda 21, the Rio Declaration on Environment and Development, and the Statement of principles for the Sustainable Management of Forests were adopted by more than 178 Governments at the United Nations Conference on Environment and Development (UNCED) held in Rio de Janeiro, Brazil, 3 to 14 June 1992.

The Commission on Sustainable Development (CSD) was created in December 1992 to ensure effective follow-up of UNCED, to monitor and report on implementation of the agreements at the local, national, regional and international levels. It was agreed that a five year review of Earth Summit progress would be made in 1997 by the United Nations General Assembly meeting in special session.

The full implementation of Agenda 21, the Programme for Further Implementation of Agenda 21 and the Commitments to the Rio principles, were strongly reaffirmed at the World Summit

on Sustainable Development (WSSD) held in Johannesburg, South Africa from 26 August to 4 September 2002.

The [video](#) Agenda 21 For Dummies is an excellent background overview.

New York State is a "[Home Rule](#)" jurisdiction, dating back to 1923. [New York Municipal Home Rule](#) - Article 2 - § 10 General Powers of Local Governments to Adopt and Amend Local Laws, provides the authority for the cherished prerogative of communities to control their destinies. The stark conflict of local self-determination and the arbitrary imposition of bureaucratic fiat outlined in Agenda 21 are self-evident. Under the guise of streamlining energy siting and land use, New York State has jumped to the tune of the globalist marching band orders. In the darkness of midnight in a closed room, the new governor Andrew Cuomo pushed a secret version of [Article X](#), and the legislature voted approval for the Power NY Act.

NY Senator [Patricia Ritchie's](#) opposition explains the violation on *Home Rule*. Assembly representative [Sean Hanna's](#) passionate argument against this attempt to diminish *Home Rule*, echoes the sentiment. But, when it comes to lining the pockets of the latest robber barons, the role of corporatist power broker law firms, like Albany's [Whiteman Osterman & Hanna LLP](#), is quite evident.

The new Article X also makes provision for post decision challenges and imposes procedural and substantive limits on potential claims. The bill prohibits the use of intervenor funds for litigation purposes. It also provides that aggrieved parties must seek rehearing at the Siting Board before approaching the courts. Judicial challenges must be brought in the courts of the Appellate Division, bypassing the trial court level, within 30 days from the issuance of the Board's decision on the application for rehearing. The bill also provides for deferential review under the "substantial evidence" standard. Finally, the new law largely divests the state courts of jurisdiction to determine any cases that seek to stop or delay construction of a generation facility that has received a certificate from the Siting Board.

The [video](#) of developer Ecogen's Testimony before the NYS Public Service Commission clearly demonstrate how citizen participation is surgically removed from the rush to rape the land and bury the serfs under the cover of a green canopy. This example of a bogus Agenda 21 corporate welfare scheme to defraud the public and feed the greed of foreign plutocrats stands squarely against the property rights of individuals and local communities. The [Wind Power Law Blog](#) identifies salient elements in the legislation.

The famous (or infamous depending on one's point of view) Article X, which provided for the streamlined siting of power plants, expired in 2003. The old Article X covered plants with 80MW or more of generational capacity. The new law should permit much faster siting of power plants of only 25MW or greater capacity. It passed both the Assembly and Senate with overwhelming margins.

Governor Cuomo styles the new law as "An Investment to Create More Power in New York"

Streamline the permitting process for power plants greater than 25 megawatts by creating a



Continues on Page 46

Continued from Page 45 - Agenda 21 in New York State

"one-stop" multi-agency siting board that will make siting decisions

Empower communities to participate in the process by requiring power plant applicants to provide "intervenor funding" for the community affected by the proposed plant to hire experts and lawyers

Improve the environment and public health by requiring the siting board to determine whether a proposed facility will create a disproportionate environmental impact in a community and, if so, requires applicant to minimize or avoid those impacts

The [Community Environmental Legal Defense Fund](#) recognizes the inherent conflict in fast tracking unbridled and reckless land development exploration for inefficient energy projects.

We believe that we are in the midst of an escalating ecological crisis, and that the crisis is the result of decisions made by a relatively few people who run corporations and government. In doing so, communities must challenge and overturn legal doctrines that have been concocted to eliminate their right to self-government, including the doctrines of corporate constitutional rights, preemption, and limitations on local legislative authority. Inseparable from the right to local self-government - and its sole limitation - are the rights of human and natural communities; they are the implicit and enumerated premises on which local self-government must be built.



Article X has another deceptive purpose. Hydrofracking drilling for natural gas in the Marcellus Shale region of NYS is the immediate underlying motive to obviate *Home Rule*. A [Frack Alert video](#) from the Home Rule Forum makes the case for the danger of losing local control of land use. Citizen community indignation is brewing up all over the state. [Watch](#) the reaction and outrage from ordinary people, who are in danger of being forced off their land. When the potable water from the aquifer is no longer fit for human use, because of chemical pollution from the fracking process, who will adjudicate relief? Another legislative appeal why the State Should Respect "Home Rule" On Drilling, comes from State Senator [James L. Seward](#):

"The topic of drilling in the Marcellus Shale has elicited an overwhelming response with

varied opinions on all sides of the issue. One thing that cannot be discounted moving forward is the desire of local residents," said Senator Seward. "That is why I am co-sponsoring legislation (S.3472) that would empower local governments and allow them to regulate natural gas drilling through local planning and zoning."

If the political intrigue in New York State does not move you to action for protecting your own homestead, maybe you should focus upon the linkage that this brutal policy of usurping local authority, has within the Agenda 21 plans for all of us. [Tom DeWeese](#) identifies, Who is behind it?

ICLEI – Local Governments for Sustainability (formally, International Council for Local Environmental Initiatives). Communities pay ICLEI dues to provide "local" community plans, software, training, etc. Addition groups include American Planning Council, The Renaissance Planning Group, International City/ County Management Group, aided by US Mayors Conference, National Governors Association, National League of Cities, National Association of County Administrators and many more private organizations and official government agencies. Foundation and government grants drive the process.

The entire substructure of alphabet soup, state and federal agencies, are on notice to facilitate and implement the systematic purging of local independence. Governor Cuomo left out the true meaning of the Power NY Act. "*An Investment to Create More Power in New York*" is designed to consolidate central planning under the control of Agenda 21 dictates. This bill has little to do with fostering cheap dependable energy, but has everything to do with neutering your local town board. This policy is not about energy. Look into why New York State rejected the low cost guaranteed electricity proposal from Canada.

"New York backed out of a long term contract with [Hydro Quebec](#) – a contract that was needed to justify the construction of the "project of the century," the James Bay II project. As a consequence, Hydro Quebec put its planned James Bay development "sur la glace" ("on ice") and activists celebrated the victory and moved on to other issues."

The Wall Street criminal syndicate lusts for their [cap and trade](#) mandates so that the next financial bubble can start the next cycle of fleecing the public. Remember that your own local government is viewed as an impediment to the Agenda 21. Soon your town board will be inoperative, iced in the same manner as economical energy from O Canada . . . 🍷

<http://www.batr.org/totalitariancollectivism/071011.html>

[Make a Comment](#) • [Email Link](#)
[Send Letter to Editor](#) • [Save Link](#)



Sustainability in All Things except Rational Thinking

By SARTRE – July 24, 2011

[Make a Comment](#) • [Email Link](#) • [Send Letter to Editor](#) • [Save Link](#)



FEW words stir up passion and polarization like sustainability. The [EPA](#) offers up this description. “The traditional definition of sustainability calls for policies and strategies that meet society’s present needs without compromising the ability of future generations to meet their own needs.” Gee, who could disagree with such touchy and feely sentiments? The answer is always in the details and when you strip away the platitudes, what remains is a coordinated plot to enslave humanity under a burden of a Carbon Tax scheme. The environment has more risk from globalist central planning than from any fossil fuel emissions. Proponents of the global warming religion demonstrate a disdain for rational thinking that challenges their doctrine of a heterodox belief. The sustainability cult ignores any evidence that conflicts with their political agenda.

The accomplished author [Robert Bryce](#) cites in *Forbes*, *A New Study Takes The Wind Out Of Wind Energy*.

“For years, it's been an article of faith among advocates of renewables that increased use of wind energy can provide a cost-effective method of reducing carbon dioxide emissions. The reality: wind energy's carbon dioxide-cutting benefits are vastly overstated.

But if wind energy doesn't significantly reduce carbon dioxide emissions, then critics can easily challenge the industry's hefty subsidies, which include the federal production tax credit of \$0.022 for each kilowatt-hour of electricity. That amounts to a subsidy of \$6.44 per million BTU of energy produced. For comparison, in 2008, the Energy Information Administration reported that subsidies to the oil and gas sector totaled \$1.9 billion per year, or about \$0.03 per million BTU of energy produced. In other words, subsidies to the wind sector are more than 200 times as great as those given to the oil and gas sector on the basis of per-unit-of-energy produced.

If those fat subsidies go away, then the U.S. wind sector will be stopped dead in its tracks. And for consumers, that should be welcome news.”

After years of exposing the industrial wind fraud, most card carrying “Green” purists reject all proof that wind factories are useless and unnecessary. This perverse anti-intellectual conduct is systemic in the simplistic and emotional realm where tree huggers reside. Sincere and pragmatic environmentalists recognize that the planet can and will survive all that man can do to disrupt the eco balance. However, sustainability theorists refuse to acknowledge that the true danger is that humanity is under universal assault by the originators of all the carbon-based myths.

By ignoring the primary nature that the Global Warming hysteria, is a political attempt to deceive and control, the indoctrinated and easily influenced are led to slaughter.

The videos [Global Warming Carbon Politics](#) and [Global Warming and the Carbon Tax Scam](#) clarifies the differences between the radiant rhetoric and the ruthless reality of the planned global taxation tribute. If you believe there is a correlation between paying a carbon tax and the saving of the planet, you are too stupid to

Global Warming Carbon Politics



Global Warming and the Carbon Tax Scam



understand the ways of the world. For such eco fanatics, the question they need to answer is what stops you from giving up all electric use and revert to [Rousseau's](#) state of nature? Sensible environmentalists recognize that [Hobbes'](#) assumption that human nature is naturally competitive and violent, face reality with maturity and a healthy skepticism.

The problem with the stereotypes and impressions of the meaning of sustainability is the flawed supposition used by the EPA and most proponents of *greening the world*. Sustainability calls for policies based upon government action that is inherently unsound. Government by nature is a destructive force. It creates nothing of value. All bureaucracies fail in comparison to a true free market. In the corporatist environment that rules political strategies, the only beneficiaries of sustainable public policy are the transnational monopolies.

Conglomerate organizations make the policy that government adopts and invariably forces people into becoming compliant consumers. The individual as a customer is a facade, especially when it comes to energy usage.

A classic article by [William S. Lind](#), *A modern-day Luddite* argues that computers deaden our souls, also applies to the environmental sustainable mindset.

“The first Christian principle, and the first principle of Western civilization, is that there is and can be only one reality. If there can be multiple realities, we lose both Jerusalem and Athens. If there can be more than one reality, there can be more than one God; so falls Jerusalem and monotheism. If there can be more than one reality, what is logical in one means nothing in others, where logic itself may not hold; so falls Athens and reason. All things are indeed relative where realities proliferate.

Continues on Page 48

Continued from Page 47 - Sustainability in All Things except Rational Thinking

Hell has always hated reality, for in the real world, Christ is King. Old Screwtape's problem, for millennia, was that philosophy made a poor weapon against reality. Even Hell's most sophisticated philosophical device, ideology, fell sure prey to reality, seldom lasting more than a couple of generations. His Wormship knew that he needed a more powerful and enduring weapon than philosophy could provide. He needed convincing but false images of the true: virtual realities."

The virtual reality that the global warming zealots profess violates the cardinal principle of Western tradition by making the twisted creed of sustainability their god. [C.S Lewis](#) converted back to Christianity and was influenced by his colleague and friend J. R. R. Tolkien and the writings of G. K. Chesterton. His journey is a chronicle of redemption and instructive wisdom. The cohorts in the sustainability legion dismiss the first principle because their Screwtape preachers bend their Wormwood brethren into becoming "Green" comrades.

[George Carlin - Saving the Planet](#)



'Sustainability' means Fascism and Depopulation



The video of the late George Carlin tells the tale of [Saving the Planet](#), in colorful language. Alan Watts expresses the real substance of '[Sustainability](#)' means [Fascism and Depopulation](#) in the next video.

For sustainability to have a valid meaning, it must start with affirming human beings first. How can a planet of created individual mortals survive when they willingly abandon their own soul? The elites intend to condemn you and your offspring's to subsistence level survival at best. The fictitious guilt trip they promote is illogical. Rational and prudent business practices to develop and use the abundance of fossil fuel resources are not only sensible but also necessary. Eliminating coal to fuel electric generation is a viewpoint that qualifies for psycho treatment in an asylum.

Did you ever wonder that the technology that allows for placement of satellites into earth's orbit would be impossible without the use of

fuel derived from those nasty carbon based substances? Maybe the irony is missed by the "Save the Planet" crowd because they are too busy watching the Green TV channel or polluting the cell frequencies and internet bandwidth. Their message of sustainable compromise of the present population, in order to reduce future generations from ever being born, is absurd. Without an affordable price for energy, our society cannot support a level of acceptable and sustainable prosperity.

Beware of outlandish promises of technological miracles. Burning wood for heating your home is now becoming an essential alternative. How long will it be before the sustainability lobby distorts the language to condemn wood as a non-renewable resource?

The Luddite philosophy needs to be examined in depth before it is condemned. Since this post industrial age is rapidly becoming a [global gulag](#), the basic survival practices of the past need to become the skill set learned, once again, in order to subsist. The future standard of living is headed for a momentous collapse. The carbon tax is designed to accelerate that downward spiral process.

Fellow Americans, do you still have doubts? View this [Carbon Tax](#) summary from down under. Australians get it, why are so many of our neighbors so dense? Just maybe George Carlin had it correct . . .

It is long overdue for citizens to become as independent as possible from corporate controlled energy dominance. A safe and clean environment is important, but that goal cannot be achieved as long as the [General Electric's](#) of the world are drafting energy policy, receiving government subsidies and charging you for the privilege of using their toxic mercury fluorescent light bulbs.

One conclusion is completely clean. The current political system is out of control and does not serve or benefit the interests of our citizens. Industrial wind and corn ethanol are creations of a mindless wishful hoax. Natural gas is more than a temporary alternative. However, the fracking drilling process only maximizes the financial interests of cousin corporatists. The Carbon Tax end game will destroy more people than the most harmful emissions from a coal plant.

Since America is now out of man space exploration, isn't it time to direct our energies in producing CHEAP energy that is benign to the environment and allows for national independence and regional autonomy based upon local needs and resources? If you want this nation to achieve real sustainability, it is important to abandon the globalist formula of phony environmentalism and damaging renewable schemes. Do you have the courage to apply rational thinking or are you just another causality of their media *sniffing glue* propaganda? 🐶

[Make a Comment](#) • [Email Link](#)
[Send Letter to Editor](#) • [Save Link](#)



How To Start Your Garden/Mini-Farm

By Donna Hancock

[Make a Comment](#) • [Email Link](#) • [Send Letter to Editor](#) • [Save Link](#)



MOST of us, if we are lucky, have had some REAL fruits and vegetables in our lifetime. Not the stuff that sits on the grocery store shelves for days or weeks that has not ripened, or has been genetically altered in some way and tastes like cardboard. But the

REAL thing. The produce that has had a lot of generational integrity and has been cultured by you to maturity. I am talking about gardening! Although gardening has been around for eons with lots of success and tried and true methods, it has truly become a lost art in the last century. Especially with the dawn of the industrial age and the processing of our foods, much of the real nutrient content in our foods has all but evaporated. We may choose to grow some or all of our own foods for various reasons, such as for taste, for health, and/or for knowledge. Whatever your reasons are, we all benefit from sharing our experiences with others about what we have actually done. On that note, I would like to share with you my gardening experiences that I have had over the last couple of years so that maybe you will learn a little bit (or a little bit more) about the subject and move into action. My knowledge base will take you from plotting out your garden to harvesting your crops and just about everything in between.

First of all, you will need to decide when you want to plant your garden. There are so many factors that come into play when making this determination that there are no set dates for planting. One main factor is determining the best time to plant for the area you live in. If you want a spring garden, this means that you will harvest your vegetables in the spring and will need to plant your seeds in the latter part of winter. Summer gardens will need to be planted in the first part of the spring (after the final frost), and fall vegetables need planting in the mid to late part of the summer. When planting spring vegetables, make sure that the weather is around 50 degrees in the evening. When the weather gets a little warmer (evenings at 60-70 degrees) it is a good time to plant summer vegetables. When you see labels that say whether something is a 'warm' or 'cool' season crop, this refers to the outside temperature and not necessarily the time of year. Vegetables that may not be ready to plant in one part of the country may work very well in another part of the county during the same time of year. So temperature is a major factor when planting because seeds will germinate (sprout) much easier if they have the correct temperature. Look at the instructions on the seed packets for guidelines as to when is the best time to plant. Some general guidelines exist, however, and you can apply them in making a determination of what to plant and when. For example, cool crops are those that can be planted in the spring such as lettuce, Brussels sprouts, cabbage, onions, cauliflower, and broccoli. Warm crops are those that won't survive a late frost without some kind of protection, and will do well in warmer temperatures. They include vegetables like eggplant, tomatoes, and peppers. Tender crops, such as melons, squash, and cucumbers can be planted early spring/summer, but will need to be covered when they are germinating to help keep the soil warm. If you live in a cool climate or want to start your seedlings indoors, you will need to start them about a month before they will be ready to plant in your garden and about 2-2.5 months before you want to harvest them. You can plant the seedlings in anything from small paper cups to something more elaborate such as seed starting wafers ([Wonder Soil](#) offers several to choose from) Whatever you decide to start your seedlings in, make sure the soil is good (gardening soil will work - you can purchase this at any hardware or



home improvement store, or use Wonder Soil's expanding soil wafers) and keep the seedlings warm and moist while they are germinating and growing. When seedlings get to be about 3" high, then they are ready to transplant into the garden. (More on this later).

Next, you will need to start by picking a place with which to do your gardening, whether it will be in a plot/pot/bucket/container/hanging basket...whatever. This step is important, but also the one that we have the least control over to some degree, because you must make good use of the area that you wish to grow your vegetables, fruits, spices, etc...to make sure your plants get the necessary light for you to get the maximum yield.



WEST SIDE OF HOUSE BEFORE PLANTING/FENCING

You will need a good amount of sunlight for your vegetables to grow, so make sure you can give them at least 6 hours of sunlight a day. Remember - sunlight is food for your vegetable plants and if you don't feed them enough, then they will suffer (and so will you). Leaf and root vegetables (such as kale, carrots and lettuce) will tolerate some shade while vegetables that produce fruit (tomatoes, peppers, squash, zucchini) need full sun. That being said, I live in the heart of the Sonoran desert where we have an abundance of sun - and heat. I have placed my tomatoes, for example, where they will get at least four to six hours of direct sunlight. But in the afternoon, when it is ridiculously hot, the tomato plants are shaded by a tree and they are doing very well and I would imagine that they appreciate some shade! The tomato plants get

Continues on Page 50

Continued from Page 49 - How To Start Your Garden/Mini-Farm

enough direct sunlight and are also supplemented by solar ambient light (rays from the sun that bounce off of surrounding objects) that the plant will still get the necessary amount of light that it needs for growth, but the tomato plants really struggle when they have full, direct sun all day in a very hot environment. They will do better in full sun if the temperatures are not so scorching hot. On the other hand, I also have a watermelon plant that gets only a little shade in the early morning, but gets full sun late morning, afternoon, and early evening. And it is growing like crazy, so it depends on the plant and what it will tolerate. You will get to know the 'personalities' of some varieties over time as you do your gardening year after year, and it will become easier to know what they like (and what they don't like). That is why it is so crucial to learn some basic gardening principles while we still have a food supply to back up whatever goofs we make in the garden. If it ever gets to the point to where we are relying solely on our gardens and our stored foods for our short or long term sustainability, it is a good thing to know ahead of time what and when things will grow so that we are ahead of the learning curve and our chances of maintaining a healthy existence in the midst of chaos will greatly increase.

Thirdly, you will need to prepare your soil. Some of the reasons to prepare the soil are to loosen it up, to strain out unwanted elements such as rocks and grass, and to allow for better nutrient absorption. To help prepare the soil, a rototiller makes the job a whole lot easier. If you are starting completely from scratch and will be digging up part of your yard to make into an area for gardening, then it is a good idea to rent a rear tiller from your local equipment rental store (this is a larger, more powerful tiller that will dig deeper than something like a smaller Mantis rototiller).



Before tilling, water the area you are going to dig first and let it soak in for a day to soften the soil, then use the tiller to tear up the soil. Once the soil is loosened, then you will need to sift the dirt to get rid of the grass, weeds, rocks, etc...



You can purchase a piece of metal mesh screen for sifting (we used an old piece of hard steel mesh that was leftover from when we built a tailgate for our trailer, and it works great as a sieve to strain out all the stuff we didn't want in our soil). A large wheelbarrow is helpful here to have something to sift the dirt into, but if you don't have one, you can try putting the mesh screen on top of some old milk crates and shoveling the loosened dirt on top of the screen so that it will fall thru the screen back onto the ground. When you have finished sifting all of the dirt in your garden plot, make an appointment with the local massage therapist because your back will be killing you at this point. After you are able to stand up straight again, take a garden rake and spread the sifted soil evenly over your plot.

Next, you will need to fertilize the sifted, raked soil. There are many sources for garden soil fertilizer, such as: 1) Your own compost (if you have the time for it, but the compost you use has to be broken down organically so that it is useful for feeding your garden plants); 2) Local compost (there are always things like this on Craigslist - you just type in manure, and you will have all that you need. You just have to go get it! But keep in mind here that this fresh manure needs to break down - or decompose - too. You will need to really plan ahead here because the fresh manure will need to be put in the garden plot a season or two earlier so that it can decompose. Technically speaking, decomposition is a biological process that includes the physical breakdown and biochemical transformation of complex organic molecules of dead material into simpler organic and inorganic molecules. That's too much technical information, but just know that the soil needs to go thru a regeneration process to where it will change the complex organic material into simpler organic material that can be used by the plants. Just like anything else in gardening, there are different ways of composting ([cold vs. hot composting](#) for example). Using fresh, uncomposted manure on your garden will burn the leaves and roots of your growing plants - too much nitrogen and ammonia. Plus, it stinks...), or 3) What I usually do is go buy steer manure by the bag from the local hardware or big box home improvement store. It is ready to use (has already decomposed), and you can't beat the price at \$0.97/bag.



However you decide to fertilize your garden soil, make sure that the soil remains loose and not packed. That way, the nutrients and water will have an easier time getting to the roots once you have your plants in the soil. Again, use a garden rake to mix the sifted soil with the fertilizer of choice and spread the mixture as evenly as you can over your garden plot so that you minimize making hills and valleys in your soil. Otherwise, when you water your garden, the water will pool up in the lower level areas which may take it away from where you want the water to be. Try to keep from walking on the freshly tilled and fertilized soil as much as you can. It will be difficult to keep totally off of it in

Continues on Page 51

Continued from Page 50 - How To Start Your Garden/Mini-Farm



STEER MANURE

light of the fact that you still have to put your seeds or seedlings in the soil, but try to keep it at a minimum so that the soil remains loose.

Next, you will simply want to water the garden plot that has been tilled and is now fertilized. You want to get the soil pretty wet so that the water can soak in a few layers deep, but not so much that you are flooding the soil. I usually water the prepared soil late in the afternoon and let it just sit for a day or two after fertilizing with the steer manure, and watering it so that the nutrients from the manure will begin to leach into the ground.

Now, you will need to decide what you want to grow and how you want to start the plant(s).



You can either plant the seeds directly into the ground, or you can transplant seedlings into the ground once the seeds have germinated/sprouted, or you can buy the seedlings from a local nursery that are ready to plant).

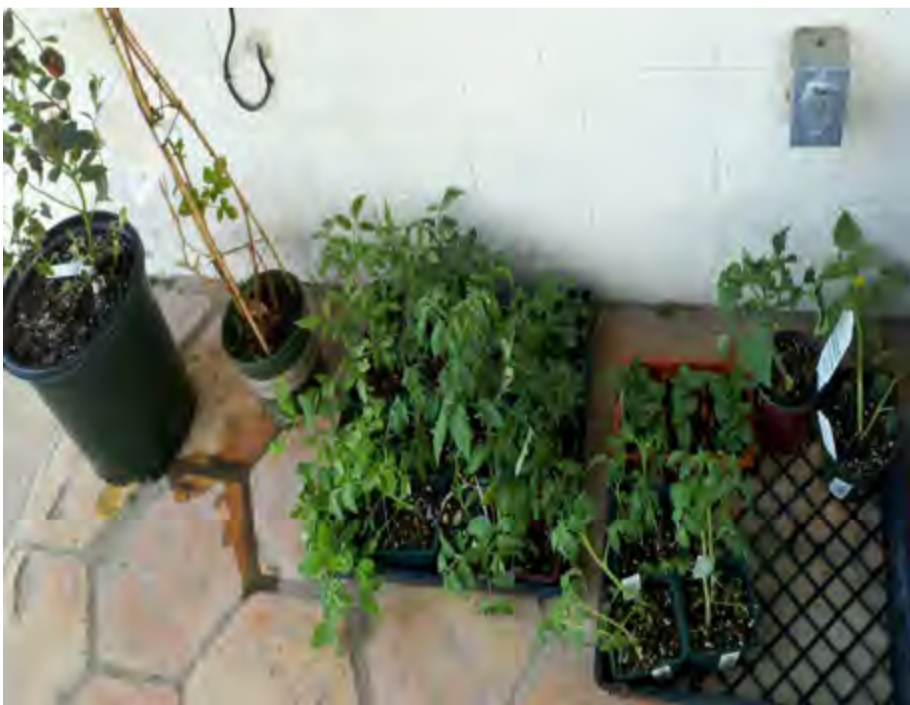

I have had better luck planting the seeds directly into the prepared soil because they don't suffer from transplant shock (yes, transplanted seedlings are very sensitive to any changes in temperature, light, moisture, etc.. and many times will have a hard time adapting to a new environment). Also, another thing to consider is what type of seed(s)/plants you want to harvest - by that I mean do you want to plant only seeds/seedlings that are from nature and/or have natural mutation, or are you going to use some type of genetically modified product? I can only guess here, but I would imagine that most of us would



want to use the natural, unmolested, unchanged seeds/plants - they are called Heirlooms. A more correct description here would be [non-hybrid](#). This is a very important issue that has come up over the years because it is becoming increasingly more common to find the GMO (Genetical-

ly Modified Organisms) seeds/foods than the natural, unchanged varieties. The companies that provide the hybrid, GMO seeds/plants have engineered these seeds/plants to produce their own 'pesticide' so that they are resistant to bugs and many things that would destroy the plant while it is growing. On the surface it sounds good, but that's where the goodness ends. When you eat the produce that comes from this type of GMO product, you are eating a genetically engineered organism that actually becomes part of the bacteria in your digestive tract. While the long term effects of eating these GMO's are not yet fully known, scientists do know one thing for sure and that is consuming genetically modified plant DNA leads to the development of GMO microorganisms which reproduce continually inside the human body. The long term consequences could be deadly, and at the very least seem to have some type of incompatibility and/or insufficiency in the body in providing the perfect balance of nutrients at the microscopic level. Also, when you plant large crops with these GMO's, they contaminate and cross-pollinate any natural/heirloom varieties that may be in the area and turn the heirloom crops into genetically modified crops.

Once you decide what you want plant, you will need to decide how you want your garden to be layed out. The very first garden I did several years ago, I took a 16'X20' plot and planted the whole plot with seeds. Sounds good, but what I did not realize until later was that it was very hard to walk thru the garden without messing up the soil and getting muddy. So what I have done in successive gardens was to plot out smaller sections within the main garden plot that I would outline with old remnants of carpet or strips of coroplast to use as walkways. I made the smaller sectioned out plots about 3-4 feet wide so that I could reach all the way into the smaller plot from either side.



That way, it is easier to plant, easier to do the weeding, easier to feed the plants, and easier to harvest. Now for the actual planting. If you are going to plant your garden from seeds sewn directly into the ground, it is best to follow the planting instructions on the seed packet for seed spacing and depth. If you will be transplanting seedlings you started weeks earlier, make sure the soil is moist before laying the seeds or transplanting the seedlings. Many ask about how deep to plant your seeds, but in general, a good rule of thumb to go by in knowing how deep to plant your seeds is plant them 2-3 times the diameter of the seed. Then, loosely cover with soil. It's ok to press down on the soil a little bit just to set it in the soil, but don't press on it so much that you have compressed the soil with the seeds into a brick. Once you have put in all your seeds, you will want to lightly water them.

Continues on Page 52

Continued from Page 51 - How To Start Your Garden/Mini-Farm

In damp climates, you may just have to do this once every couple of days or once a week. In the desert and drier climates, you will have to really be diligent about keeping the soil moist (but not flooded) and that means lightly watering it a couple of times each day. Do not let the soil dry out OR get too wet. If the soil gets too dry, the seeds won't germinate, and if the soil is too wet, the seeds/plants may get moldy and/or rot. Now if you want to start the seeds in Styrofoam cups



or in seed starter containers first until they become older seedlings, the same principle applies in that it must be good, rich soil and that the soil must be moist before putting in your seeds. If using a cup or seed starting container, you won't need much

soil at first here to get the seeds started. A bag of garden soil will do the job. Fill each cup/seed starter with garden soil, moisten it (a couple squirts of water from a spray bottle work well for this), put two seeds into each cup/seed starter and lightly cover seed with more gardening soil.

You can also buy seed starters that are the soil



(seed pellets or seed plugs) and for these products, you put the seed directly into the pellet/plug and spray with water. Either way that you try to plant your seeds, make sure you plant two

seeds in each hole. I didn't understand this at first, but the reason we are told to plant two seeds instead of one seed in each hole is so that you will have a better chance that something will sprout (if one seed doesn't make it, the other one will).

Once you have planted all the seeds and/or transplanted the seedlings into the garden, it's a good idea to map out what you have planted and where you have planted them in the garden by writing it down on a sheet of paper. Sometimes, you might plant two or three types of peas, for example, and you want to know which one you like best or which one does better for your climate, so if you mark everything down, you will be able to keep track of it.

Another minor thing to consider here is that you may want to stagger planting certain things within the same growing period. For example, if you want to plant lettuce, pick out a spot where you want to plant it, sow lettuce seeds into 1/3 of that area, then in three weeks sow the next 1/3, and in another 3 weeks or so, sow the last 1/3 of the lettuce plot. That way all your lettuce will not be ready all at once, but you will continue to get a new crop even after the first one that was planted is at the end of its usefulness.

Now, once you have finished planting and/or transplanting, you will do a lot of waiting, weeding, and feeding. If you have planted seeds directly into the soil, it is always exciting to see them sprout (some usually within several days). If you have transplanted seedlings into your garden from small containers, a little boost



B-VITAMIN TRANSPLANT SOLUTION

of B-vitamins will help with the shock of being moved. Also, you will have to keep up on the weeding, because as you know, weeds are very easy to grow and if you are giving the garden plot lots of nutrients, the weeds will always find a way there. Also, most home gardeners do not want to put

pesticides or weed killers in their gardens because of the dangers they pose to their health. The reason you want to keep the weeds out of your garden is that they compete for the water and nutrients you are feeding to your vegetables. Some of the weeds can get very large very fast and they take up a lot of space and crowd the garden so that the vegetables also have to compete for space with the weeds. You will also need to 'feed' your garden plants a number of different chemical elements, mostly nitrogen, potassium, and phosphorus, which are the main ingredient in plant food. They also need air and water. Please go to [What is fertilizer and why do plants need it?](#) for some great information on the components of fertilizer and how you can see what ratios of these elements are in certain plant foods. There are several commercial plant and garden foods available. I have used fish emulsion in the garden about once a month to help boost the nutrient content for the garden plants. That is what makes aquaponics so successful



FISH EMULSION

because it uses fish waste (which can be toxic to fish in high concentrations), and delivers it to the plants (usually fed thru some type of tubing system). The plants can then use up the vital nutrients in the fish waste and by doing so, it will cleanse the water. Then the water is recirculated back to the fish tank/pond and is now clean water for the fish. Go to [Fish Emulsion](#) for more information. Another reason to use natural and organic fertilizers and soil amendments: earthworms love them. Earthworms are extremely beneficial in the vegetable garden; increasing air space in the soil and leaving behind worm castings (worm poop). Do what you can to encourage earthworms in your soil. You can get them wherever you get fish bait. Also, there are insects that are good for your garden as well. Many insects can simply be a pest, eating everything in sight, but there are four insects that are good for your garden: 1). Bees - As discussed earlier, bees are good pollinators. They help your garden plants develop into tasty vegetables; 2). Dragonflies - While pretty to look at, dragonflies will eat pesky mosquitoes and other garden pests that can be destructive to your garden plants; 3). Praying Mantis - The praying mantis will eat whatever it can catch (will eat the good bugs along with the bad); and 4). Ladybugs - Ladybugs can eat a lot each day. They can eat tons of aphids and will feast on other garden pests and larvae. While encouraging some of the garden-friendly insects listed above can help keep your garden from being overrun by destructive garden pests, you can also try [Food Grade Diatomaceous Earth](#) (technical term is fossilized phytoplankton powder). DE is a microscopic dust that has razor sharp edges and to small insects, it will pierce their exoskeleton and cause them to dehydrate and die. It is not a

Continues on Page 53

Continued from Page 52 - How To Start Your Garden/Mini-Farm

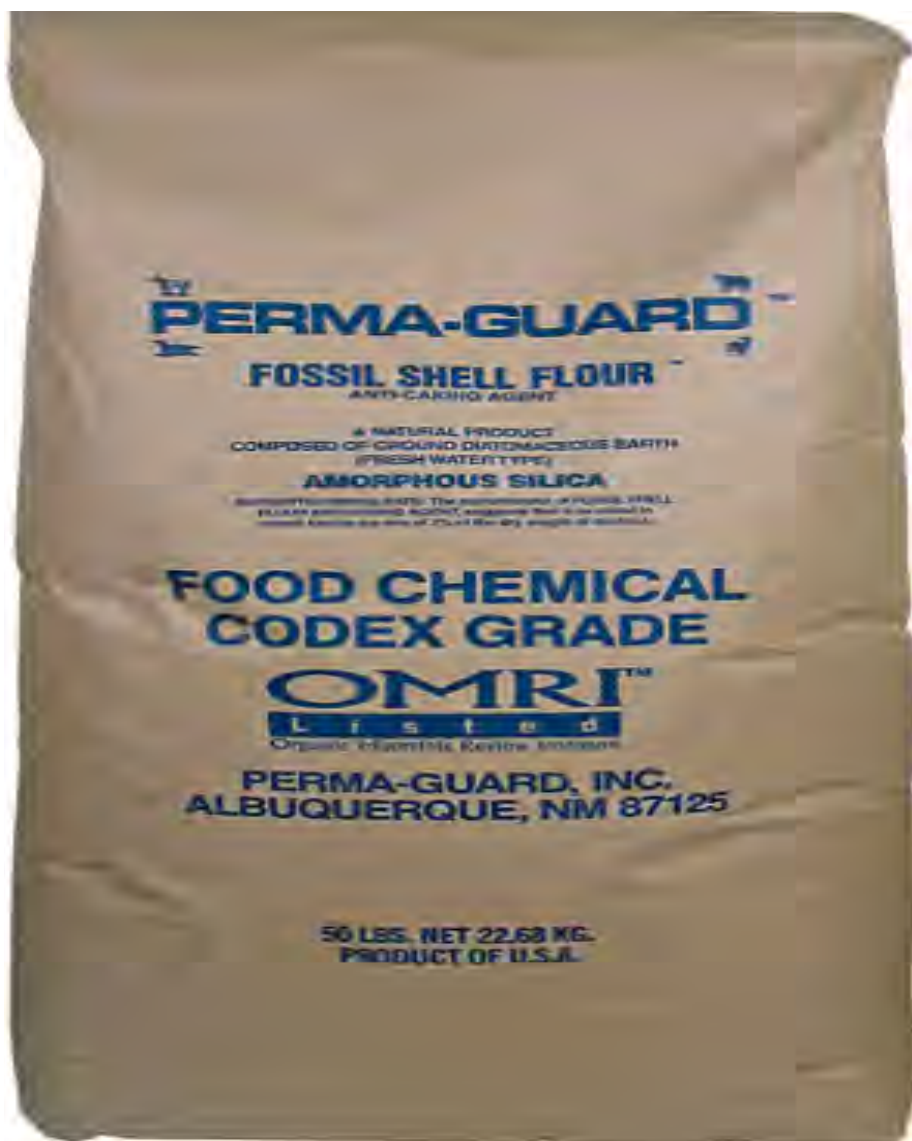

Food Grade Diatomaceous Earth

poison, but rather works by mechanical means to get rid of unwanted critters around your garden (and house, for that matter). It is safe for humans and animals, however it is best not to breathe this fine powder as it may aggravate the mucous membranes in your nose and mouth. Also, if you have gophers in your garden, it will be tough to get rid of them, but here are some of the things to try. Some gardeners swear by marigolds and green onions, for which gophers are said to have a particular distaste. Experiment by planting marigolds and green onions in and around your garden to discourage gophers from coming around. Mothballs, garlic, spearmint leaves, and a perimeter of mole plant or castor bean planted around gardens have all provided mixed results. Some say putting ammonia down the gopher tubes helps, or just get a cat and see what happens. These control strategies may be experimented with where gophers are an occasional problem, but they are generally not a long-term solution. For keeping birds out, bird netting works well, is readily available, and is fairly inexpensive. So it is important to know which things are detrimental and which things are beneficial to your garden. It is really frustrating to go thru the process to get to the point where your vegetables and fruits are just getting ripe and all of a sudden, they are eaten up by pests (large and small) overnight. That is a lot of hard work and expense gone down the drain.

While you are waiting for your garden plants to grow, there are other things you may consider doing to help protect your garden depending on where you live, and how much you may want to 'automate' it so that you are not spending every waking moment in it. Things like fencing, shading, and an automatic drip system are just a few. **FENCING:** If you live in a rural area, you will almost certainly want to keep your garden protected from large predators (such as deer, rabbits, coyotes) so putting up a perimeter fence around the garden is essential. I live in a large city, but still put up a fence around the garden to keep the goats, chickens, rabbits, and dogs out of it. I used some old metal sign posts (have been collecting these for years after political elections when candidates would fail to take down their signs and posts and they become fair game for anyone who wants them), a post hole digger, some chicken wire fencing, and wire ties. Took a couple of hours, but it will only have to be done once.

SHADING: Next, shading the garden was an essential part of our summer gardening since we



live in a very hot, dry climate with lots of sun, but putting it up took some time. It is a semi-permanent structure, so it was a little challenging to make it work without making any permanent fixtures, but the materials I used were nine 5 ft. long rebar stakes, nine 8 ft. long 3/4" PVC pipes, eight 5 ft. long 3/4" PVC pipes, tarp clams, nylon twine, and six 6 ft. X 20 ft. shade cloths designed to filter about 70% of UV rays. To make the shade canopy, I drove each 5ft. rebar stake into the ground about 5 ft. apart with

Continues on Page 54

Continued from Page 53 - How To Start Your Garden/Mini-Farm



TARP AND FRAME

a post hammer, then slipped the 8 ft. long, $\frac{3}{4}$ " wide PVC pipe over each rebar stake and pushed the PVC into the ground about 1 foot (so now 7 ft. of PVC pipe was sticking out of the ground). I did this for the entire length of the garden and all in one straight line running the length of the garden, so now I had nine 7-ft long PVC poles sticking out of the ground at 5ft increments. Then I attached PVC t-connectors to the top of each 7 ft. PVC pole (using elbow-shaped PVC connectors on the end poles) and connected the nine 7 ft. $\frac{3}{4}$ " PVC poles together using the 5 ft PVC pipes connected to each t-connector/elbow to create a frame for the shade cloth to drape over. We put tarp clips on each corner of each shade cloth, attached 5 ft. lengths of nylon twine to each tarp clip, draped the shade cloths over the PVC frame, and tied one end of the shade cloth to a chain-link fence on one side of the garden, and the other end was tied to the metal perimeter fence posts on the opposite side of the garden. Now the shade cloth covers about half to two-thirds of the garden and by doing it this way, the temperature will be reduced by about 15 degrees which is crucial to keep the garden from getting fried out by the sun's heat. An important thing to keep in mind here is that some parts of the garden are going to be in the sun at any one time, and some of it will be in the shade. As the sun moves across the sky, it is at different angles at different times so that each part of the garden will get at least some measure of full sun every day, while also getting to be in the shade for other parts of the day. I have found this works well for me in the climate I live in. You may live in a climate that is begging for more sun and/or warmth, so you can adjust it accordingly for your area. The shade structure can also work well in the wintertime to provide protection from frost/freezing temperatures. By enclosing the shade structure you will create a little micro-climate within the structure, especially if you add a heat lamp (I use the same 250W infrared bulb used to keep baby chicks warm) on the coldest nights during the winter and it keeps the garden plants from freezing. One thing to know is that many of the garden plants will survive the cold, just not the frost. As long as they are established plants when the weather turns cold, they may grow a little slower, but they will still produce for you as long as they don't freeze. **AUTOMATIC DRIP SYSTEM:** Supplies used for the automatic drip sys-



AUTOMATIC DRIP SYSTEM SUPPLIES

tem I installed in my garden this spring are 700 poly hose, $\frac{1}{4}$ " soaker tubing, $\frac{1}{4}$ " couplings, $\frac{1}{4}$ " tubing plugs, figure 8 end clamps for 700 poly hose, hole puncher, Raindrip automatic timer, and a PVC hose coupler where one end attaches to the timer while the other end attaches to the 700 poly hose. Design how you want to lay out your watering delivery system. Each garden will be different in how it is laid out, but the main thing to keep in mind is that the 700 poly hose is the main line coming from the spigot, and many smaller soaker hoses will branch off of the main line and be where the water sweats/drips out into your garden plants. You can cut the 700 poly hose and the soaker tubing to whatever lengths you want, using the figure 8 end clamp at the end of the 700 poly hose. Use the hole punch to punch holes in the 700 poly hose where you want to connect a length of soaker tubing. Use the $\frac{1}{4}$ " couplers to attach the soaker tubing to the 700 poly hose where you punched your holes, and the $\frac{1}{4}$ " tubing plugs to plug the other end of the soaker tubing. Although this will also take some time to set up, once you do it, you can keep using it year after year and just maintain the sections that might need some attention as needed. This was a great time saver for me since I have to water twice a day in the heat of the summer. Now, I can just turn on the water for an hour in the morning and an hour in the late afternoon (or if I can't be there, the timer will turn the water on and off for me at times I pre-select).

By about a month and a half or so, your garden plants will have grown significantly (some grow out like cucumbers and watermelons and will spread out all over your garden!), some

Continued on Page 55

Continued from Page 54 - How To Start Your Garden/Mini-Farm

grow up (like tomatoes, peppers, and corn), and some grow in the ground (like carrots and onions). It is around this time that you will start to see flowers on your garden plants (at least on the ones growing out and up). These flowers are where the vegetables/fruits will grow if they are pollinated. Now this has become a very big issue as of late since it seems like many of the people that I have talked with in my little gardening community have said they have big, beautiful garden plants with lots of flowers, but not many fruits or vegetables are growing on them. I have experienced this as well, even after careful planting, watering, and fertilizing. I think one of the main problems here is that there are a lack of bees to do the pollinating. There are some that think all of the cell towers that have been put up over the years has affected the bee population, as well as a lot of growth in our cities and towns that tend to push out the bees. I can't say for sure that these things are true, but it sounds at least plausible that they might be contributing factors in the low numbers of bees being reported. Click on [Study: Cell phone radiation could be responsible for bee population decline \(Video\)](#) for some information on the worldwide declining bee population. Another factor that can contribute to low vegetable/fruit yield in the garden are extreme hot or cold temperatures. This can cause the plant to produce only male flowers and render any pollination attempts to be ineffective. So these are some of the issues that you need to be aware of when looking to get the maximum production from your planting efforts.

In this section we will look at ways to help the reproduction process along if you think that your flowers are not being pollinated. Now, there are some garden plants that are self pollinating (pollen from one flower can pollinate the same flower). Some of the plants that are self pollinating are tomatoes and peppers. There are also some garden plants that have male and female flowers, such as zucchini. But most of the garden plants need some help. In addition to bees, butterflies and hummingbirds, wind will aid in pollination. If you don't get a lot of wind where you live, you can take a leaf blower across your garden (not full blast, but enough to give it a nice breeze so that the pollen can be moved around) to help the process along. Or you could give your plant a good shaking every day or so to redistribute the pollen where it needs to go. Also, hand-pollinating (with a feather, Q-tip, or small tipped paint brush) can be used to transfer pollen from male to female flowers, or from male parts of a flower to female parts of a flower. To do this, go to [Pollination](#) for a detailed description and drawing of the inner workings of a flower, and which parts are male vs. female parts.

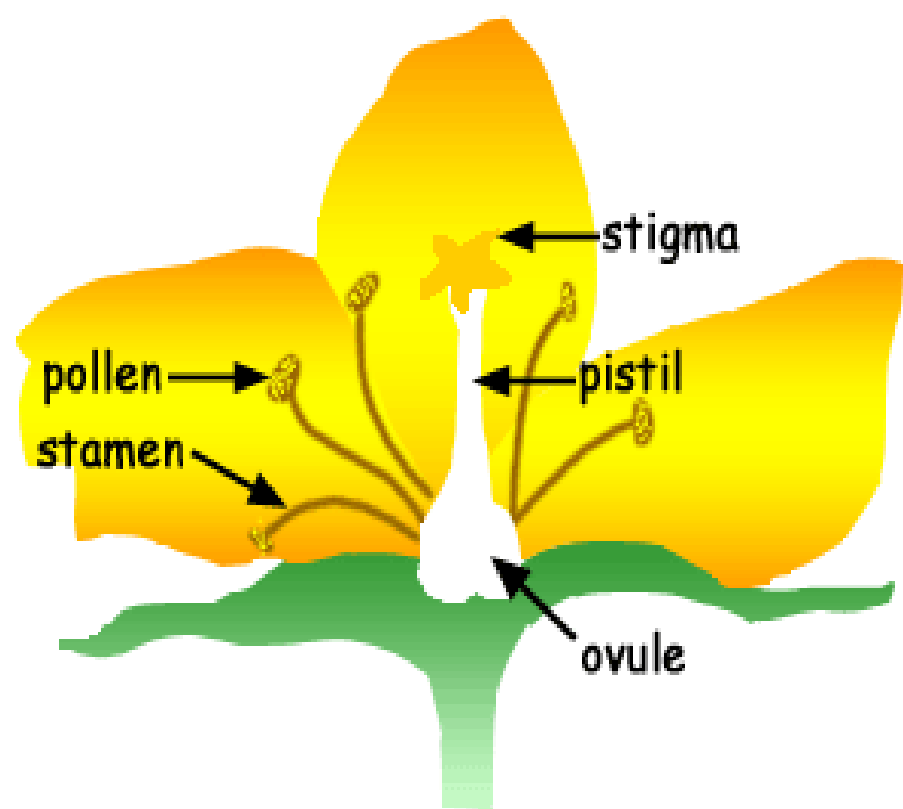

One male flower can pollinate several female flowers.



This article has dealt mostly with gardening in the ground, but I have done other types of gardening as well that I will very briefly touch on here. I tried container gardening, but it did not work very well for

me (container gardening is when you plant your seeds or seedlings in a pot or other large container) - I did it for one season in the summer and I think that the ambient temperature was too hot around the planter that it did not promote a healthy plant.

Remember that temperature is one of the key factors to successful gardening. I plan to try some container gardening in the cooler months to see if that works better. I have also done hanging plants (specifically, tomatoes). I did it for two seasons. The first time I tried hanging tomato plants was in the winter/spring season and they did fairly well, producing a number of good quality tomatoes (not as much as the in-ground tomatoes, though). The second time was in the summer here (in Phoenix, AZ). Not a good idea, because, once again, the heat was a factor in stressing out the tomato plants so that they produced very little.



Now after about 3 months or so from when you first planted your garden, you have done everything you can to ensure that your garden has what it needs so that it can provide you with the fruits and vegetables of your labor, you just have to wait until the fruits and vegetables grow to maturity. For the most part, you will know when they are ripe. If the fruits and vegetables start to wither and dry up, then you have waited too long. One of the best reasons to do a home garden, aside from the fact that you have fresh food, is that you can allow the fruits/vegetables to ripen on the vine. By doing this, you will get the best flavor, juiciness, digestibility, and nutrition. Most of the flavor and juiciness comes from the fruits/vegetables being able to stay on the vine longer so that they can grow to maturity. Also, if you are eating un-ripened fruits and vegetables, it is harder for your digestive system to break them down in your body and can give you gas. And the most important reason for giving your produce the opportunity to fully mature before you pick it is because you will get a full spectrum of vitamins and minerals in a perfect balance that your body was designed to utilize.

Our bodies were designed to operate very efficiently if we give it the right fuel. Much of our food supply has been compromised because of the mass production that leads to lower quality, pesticide filled foods that have been deprived of much of their nutritional value. Eating foods that have very little nutritional value starves our bodies of the very things that will keep it's

Continues on Page 56

Continued from Page 55 - How To Start Your Garden/Mini-Farm

immune system functioning properly. Immune system cells talk to each other and relay messages by way of an extensive network of tiny tunnels and are capable of long distance communication and information exchange. When a foreign invader is present (virus, bacteria, fungus, etc...) the cells can relay critical information very swiftly on how to deal with this invader. As a matter of fact, this happens every day. What happens when we don't eat the right foods is that these immune system cells are compromised and there is a breakdown in communication and many things are allowed to proliferate in our bodies that otherwise would be stopped. Additionally, compromised immune system cells can fail to recognize things that might be good for our bodies, but because of poor communication, will destroy healthy body tissues (auto-immune). That is why it is so important to give your body the proper nutrients so that it will promote a healthy, functioning immune system response when it is called upon to do so. Nursing homes and hospitals are full of people that have not had the proper nutrition and have all of these diseases that are causing them great pain and expense. Some examples of auto immune diseases are lupus, multiple sclerosis, psoriasis, restless leg syndrome, rheumatoid arthritis, vasculitis, celiac disease, Crohns disease, diabetes mellitus type 1, Guillain-Barre syndrome, and on and on. Chances are that we all know someone who has one of these ailments.

What you will come to learn is that gardening is a lot of hard work, but it is a labor of love

that we should all do for our families. Nothing worth having ever comes easy, and that is certainly true of gardening. But, not only will you feel better and have better tasting food, you will learn a valuable lesson in self-preservation if you understand some basic gardening principles. It takes some practice getting to know your plants, your soil, different soil enhancers and soil amendments, what temperatures are suited for certain crops in your area, and forming a community of friends, family, local community organizations, farmer's markets, etc. with which to build your knowledge base. Incorporating at least some healthy, home grown foods into your daily diet is much better than none at all. Just growing tomatoes on your patio, or some salad ingredients such as lettuce, cucumbers, radishes, etc... whatever you like just to get started is a step in the right direction. And it will prompt others who come to visit to ask questions that just might spark an interest in them to do something as well. So just do it. And enjoy better health. Waiting on you now...🍷

[Make a Comment](#) • [Email Link](#)
[Send Letter to Editor](#) • [Save Link](#)



GOT CHICKENS? By Donna Hancock

[Make a Comment](#) • [Email Link](#) • [Send Letter to Editor](#) • [Save Link](#)



RAISING chickens for egg production is an important part of a long term plan for health, barter, and survival purposes. I will share with you my experiences with raising chickens, and you will find that

they are very easy to raise, require very little care, but will produce a valuable commodity right in your own backyard. They are also great to have around because it gives young kids an opportunity to help take care and raise them and they will grow up with some basic knowledge.

First of all, decide what type of chickens you want to raise. It's a good idea to choose chicken breeds that are good natured, mild mannered (non-aggressive), and are good egg layers. There is a lot of information on the internet about different [chicken breeds](#) that will supply you with information on the most popular breeds and their individual traits (breed size, purpose, egg production, egg size, egg color, comb type, climate hardiness, broodiness, and temperament). You can order chicks on the internet for home delivery, get the chicks at your local feed store, or try Craigslist in your area to see what local breeders have available. You may want to get a couple extra chicks than you actually need since it is not uncommon to have a couple that won't survive or they end up being roosters. If you live in a rural area or have property with some acreage, you probably won't have any problems keeping roosters, but if you live within the city limits (wherever you are), you most likely will not be able to have a rooster (they are noisy). I got my first chicks (also called pullets, which are female chickens that are under one year old) almost 3 years ago from a local feed store when the chicks were a day old. You can purchase them when they are older (they'll be more expensive), but I prefer to get them when they are just born so I can raise them the way I want. Newly hatched baby chicks range from \$2.50 - \$3.00 per chick. Older ones can cost anywhere from \$7.00 to as much as \$20.00 per chicken. The second batch of chicks I got from a local breeder that I found on Craigslist. I was looking for a specific breed and this local breeder happened to have what I wanted.



LOCAL CHICKEN BREEDER

The breed of chicks I chose are red and black stars (also known as red and black sex links), and marans because they are mild mannered, non-aggressive, and good egg-layers.



2 Days Old

The 'equipment' you will need to begin raising your chicks are a small feeder and watered, some type of bedding (shredded newspaper, sand, dry leaves, or wood shavings - chicks love to root around in the litter), starter feed, a heat lamp to keep the chicks warm, and also at this stage a box or a small container.. You can get almost all of these items at your local feed store.



3 GALON - WATERER AND SMALL FEEDER



WOOD SHAVINGS



STARTER FEED

The first batch of chicks I got I kept in a box inside the house for a couple of days, then transferred them outside into an enclosed area of a home-made chicken coop. The second batch just got put directly into an enclosed area of the coop.

However you start to raise your baby chicks, you will eventually need a chicken coop. Chicken coops come in all shapes and sizes, can be homemade or store bought, and can be stationary or mobile. If making a homemade chicken coop, you can design your own, or go online to find schematics to build from. The main elements are to have a place for them to roost at night, lay eggs during the day, a place for the food and water, and have enough room to move about. Even if your chickens are free range, they will need a place to go to for sleeping and laying eggs.

An important thing to know when getting brand new, just born baby chicks is that you have to keep them warm. I use a 250 watt infrared light bulb that I hang up in the coop to keep the baby chicks warm.

You don't want to use a halogen bulb for this as it will get too hot for the chicks. The infrared

Continues on Page 58

Continued from Page 57 - GOT CHICKENS?



4 TYPES OF CHICKEN COOPS

bulb puts out nice even heat that will warm the area sufficiently without harming the chicks. The temperature needs to be kept at around 95 degrees for the first week, then decrease the



250 WATT INFRARED BULB

temperature by 5 degrees every week until they are six weeks old and are fairly feathered out. If the chicks can't be kept warm for the first weeks of their life, they will die. The nice thing here is that you don't have to do anything with moving the bulb around - the chicks will simply sit in an area of warmth that the bulb puts out that they are comfortable with so they self-regulate what temperature is good for them. It is important to note here that when the chicks become adults, they can withstand freezing temperatures, but will not do well in extreme heat.

For about the first month of their life, the chicks should be kept in an enclosed area if they are outside so that they can be kept safe from predators, and also to be kept warm. If they are kept

inside, you can just keep them in a box or container with the heat lamp on them. Keep in mind, though, they grow pretty fast so getting them used to the environment they will be living in as quickly as possible is preferable. For the first few weeks of the chicks life, all you will have to do is make sure the chicks get starter feed, plenty of fresh water, and warmth. They will grow rapidly during this time.

There are several types of chicken feed: **starter feed** (1 day to 6 weeks old), **grower feed** (6 weeks to approx. 20 weeks), then **layer feed** after that. Each type of chicken feed has the proper balance of protein and calcium for each stage or development. Additionally, chicken feeds come in three different forms: mash, crumble, and pellets. Mash is powdery, pellets are made of compressed mash, and crumbles are made from broken up pellets. I have found that mash is a waste of time and I never use it. I give the younger chicks crumbles, and the older chickens pellets. That way, whenever they kick it out of the feeder (which they will), they can still pick it up to eat. There has been a lot of debate about whether to feed your chickens table scraps to supplement what you give them in their feeder. As for me, I feed my chickens table scraps every chance I get. Not only does it cut down on the need to purchase feed, it also helps you get rid of extra food that would normally just go to waste. What did people feed chickens before there was chicken feed? !One thing you must do, however, is supplement your laying chickens' diet with extra calcium. The layer feed has extra calcium in it, but you can also add oyster shells (from feed store) or crush up egg shells and put them in the feed or table scraps. Chickens love this, and it is good for them. However, do not give oyster shell to baby chicks as it will cause bone development problems in young birds. You also need to feed chickens grain (usually cracked corn, which is available at the feed store) and you can start adding it in at the grower feed stage (6 weeks +) at a ratio of about one-third grain to two-thirds grower feed. When they get to the laying stage, they will need 50% grain and 50% layer feed. The feeds nowadays generally do not have hormones but may contain antibiotics. Feed stores carry organic and medicated feeds as well. As you would expect, the organic feeds are more expensive and are better for egg producing chickens so that any pesticides don't pass from hen to egg and then to you. Most medicated chicken feeds have [amprolium](#), which is a chicken feed additive that helps prevent coccidiosis (coccidiosis is a parasitic disease of the intestinal tract caused by microscopic organisms called coccidia. The disease spreads from one animal to another by contact with infected feces. It is most severe in young or weak animals and often causes bloody diarrhea). There is a lot of debate about whether amprolium is an antibiotic or not, but it is an additive nonetheless and you should decide whether it is something you want to feed your chicks or not. Many say that chicks need medicated starter feed, although there is a lot of discussion that says home or small farm environments do not need it. Generally, if you keep your chickens in a clean environment, then you won't need antibiotics in your feed. You will have to decide what works best for you however you decide to feed your birds. Chickens are great - you put food in one end, and they poop out eggs at the other. It's a very efficient system.

When the chicks are about a month old, you will notice that you will be having to give them much more water and feed than you did at first, so switching to a larger waterer and feeder will be necessary.

Continues on Page 59

Continued from Page 58 - GOT CHICKENS?



LARGE FEEDER



LARGE WATERER



AUTOMATIC CHICKEN WATERER

Chickens are messy and that is why a lot of feeders and waterers are designed the way they are so that it will keep the chickens from getting into the feed and water. You can get as simple or elaborate as you want, you can purchase commercial feeders and waterers or make your own. The pictures provided in this article are but a few. Find out what works best for you, and whether you want to automate any part of the operation.

The chicken coop will need a supply of litter, and there are several ones to choose from. You can use straw, leaves, sand, wood shavings, etc... You can clean out the coop regularly (every week or so) and use the litter in your compost pile (good source of nitrogen which helps break down the compost faster), or you can '[deep litter](#)', which is when you spread clean litter material over the old litter and let it build up. I use the deep litter method, since it is much easier and less costly, plus I think it is healthier for the chickens.

Some of you may only have a small area in your backyard for a coop and will keep the chickens in the coop at all times, and some of you will have a larger yard that you can let your chickens roam around in during the day (free-range chickens). Whichever way you keep your chickens, you will notice that they are constantly pecking the ground for food. What they are doing is looking for bugs, which are a great food source for them (lots of natural protein). You can always supplement their diet with a treat now and then with some worms, or whatever bugs happen to be around your yard. They will love it.

Chickens like to perch (or roost) on things, so you will notice that they will climb on top of fences, chairs, wood or rock piles, ladders... whatever is around. It is important to have a roosting bar for them to get on at night since it is their nature to sleep while being slightly elevated. They do this because it keeps them safe from some predators, so create a place in your chicken coop that they can go at night to roost and feel safe. Again, this can be a very simple set up, or you can make it as elaborate as you wish.



ROOSTING BAR



LARGER ROOSTING BAR

It is preferable to keep baby chicks separate from the older chickens at least until the babies are a couple months old. Older is better, but if you are going to be mixing baby chicks with older, laying hens, the best way to make sure

Continues on Page 60

Continued from Page 59 - GOT CHICKENS?

they both get the right feed is to make a smaller sectioned off area in the coop for the babies and cut a small hold in the chicken wire so that the babies can go in and out to get their food, but that the older hens won't fit thru. The older hens will peck at the younger ones (this is normal and where the term hen pecked came from), but they will eventually establish their own pecking order and unless you have a really aggressive chicken that is being overly abusive, it is just best to leave them alone to create their own system.

As mentioned earlier, chickens can handle a wide range in temperatures, from freezing winters to hot summer days, but when the temperature is above 90-95 degrees, they will struggle and you will need to provide a way to cool them off in the heat of the day. A popular way to do this is to freeze water in gallon milk containers at night, and put the frozen containers in the chicken coop during the day to offer the chickens a way to keep cool. What I have done is to



MISITNG STAND

purchase two misting stands, hook them up to a garden hose, and turn the water on for most of the day.

The chickens like to hang out around the misters and it will keep them cooler so that they can survive. I lost three chickens to the heat the very first year I had them, and this was an efficient way to provide a cooler environment for them. If chickens get stressed, their egg production decreases and worse, they may get sick and die. So keeping them healthy and comfortable is important.

As you can see, there are some basic things to know about chickens such as what kind of feed to give them at certain stages of their life, creating a safe environment for them to eat, lay eggs, and sleep, and basic hygiene in the area in which they live. But chickens are a great addition to anyone who would like to learn about raising and keeping them, or simply to have some healthy, organic eggs of their own to add to their diet or barter system. I would encourage anyone who has the space to get some chicks and start going thru the process of raising them. Even if you can only have a few chickens where you are, it's a start. There will be some initial output for the supplies (feeders, waterers, coop supplies, heat lamp, etc...), but once you have those items, you can re-use them each time you add another batch of chicks. You will find that chickens are very easy to raise and don't take much time at all to take care of. The benefits far outweigh any of negatives, so go get some chicks and get started! 🐔

[Make a Comment](#) • [Email Link](#)
[Send Letter to Editor](#) • [Save Link](#)

Donna Hancock's How To Start Your Garden/Mini-Farm

[Make a Comment](#) • [Email Link](#) • [Send Letter to Editor](#) • [Save Link](#)

Part 1



Part 2



Part 3



[Make a Comment](#) • [Email Link](#) • [Send Letter to Editor](#) • [Save Link](#)

JUICING TO STAY HEALTHY

By Donna Hancock

[Make a Comment](#) • [Email Link](#) • [Send Letter to Editor](#) • [Save Link](#)



THERE has been a lot of information circulating in books and on the internet lately that many of our diseases (especially in the United States) are caused by our nutrient deprived diet. Anything from cancer to joint pain has been mentioned as preventable, and at the very least treatable, by maintaining a healthy diet. There are many diets that are effective in the prevention of diseases and the premise is that we need to be eating healthy, pesticide-free, non-hybrid, un-processed foods. Sounds easy, but up until the recent past, they were hard to find. The market is shifting and answering the public's concern by offering organic foods (in the produce, meat, and dairy section), safer processing for canned goods (less or no added preservatives), and the move towards using glass over plastic. Although these subjects are all worth exploring individually, this article will talk about the benefits of juicing, specifically, the [Gerson Therapy](#)

[Dr. Max Garson](#), by accident, found cures for many ailments of his time (early to mid 1900's) when he was trying to find a natural cure for his headaches. Knowledge has grown over the years since that time to where there are now books about the subject (*The Gerson Therapy: The Amazing Nutritional Program for Cancer and Other Illnesses*), videos ([The Gerson Therapy for Cancer Explained](#) and [The Beautiful Truth](#)) and a couple of [clinics](#) that are licensed by the Gerson Institute to practice the full Gerson Therapy. What makes the Gerson Therapy so unique and effective is that it gives the cells a high dose of complete enzymes, minerals, and nutrients that in turn break down the diseased tissue in the body, while the enemas eliminate the toxins in the body. Please click on the links provided here to learn all you can about the process of preventing and curing diseases, as they are full of information that would be too lengthy to go into in this article.

I can testify to first-hand knowledge of the validity of the claims made by doing the Gerson Therapy. One is of a friend (Robert) who had cancer and was sent home to die, and the other is of my husband (Ernest Hancock, publisher of Freedom's Phoenix). As for Robert's story, he was a middle aged man with wife and kids who developed cancer and went thru the normal protocol for treatment. He was not getting better, and the doctors could do no more for him. So as a last resort because he was staring death in the face and he had nothing to lose, another friend has sent him information on the Gerson Therapy and urged him to do it for some time, so he decided now was that time. He started doing the Gerson Therapy at home with the help of his wife, and his cancer started to go away and as of this writing (it has been at least 4-5 years), Robert is cancer free and was hiking the Canadian Rockies not too long ago. And as for Ernest's story, fortunately he did not have cancer or any other serious disease, but was suffering from the effects of aging (joint pain, not

wanting to get out of bed in the morning, feeling tired all day, etc...). He decided to try the Gerson Therapy (to some degree) so that he would feel better and not feel so run down all the time. From the very first day he did the juicing, Ernest felt healthier and the pain in his joints started to go away. The nutrition was being pumped into his cells so that they could do what they were supposed to do. Ernest has been juicing for nearly two years now and feels younger than he did when he was in his late 30's/early 40's (he is now 50). There are many testimonials to this effect and they are well worth exploring.



So what is the Gerson Therapy? In short, you drink organic juice made from juicing green apples (granny smith - must remove the core as the seeds contain cyanogenic acids which can give you cyanide poisoning in the body. A few seeds won't hurt you, but in quantity they can be fatal), carrots, and some type of greens (kale, collards, spinach, etc...).

If you are fighting cancer, you would drink 13 of these juices a day, in addition to eating just a small amount of meat (all organic) such as chicken or fish, no processed foods (no salt or sugar), and you must do 3 organic coffee enemas a day (this is to ensure that whatever you are putting into your cells to push out the

Continues on Page 63

Continued from Page 62 - JUICING TO STAY HEALTHY

bad stuff gets removed from your body. If you don't do the enemas as part of the therapy, you will re-absorb some of the toxins back into the body). The juice must be freshly made with a press type of juicer for maximum benefit (such as the [Norwalk Juicer](#) or the [Champion Juicer](#)). These types of press juicers are very expensive, but cause less damage to the cells of whatever you are juicing so that they are in a more perfect enzymatic state for your body to use. You can make enough juice to last you the whole day with this type of juicer. For those on a budget, there is another juicer you can use and it is a [centrifugal juicer](#). These types of juicers are much less expensive and you will still get beneficial results, but should drink the juice within an hour of preparation for maximum benefit. For the juicing that I did, I used a centrifugal juicer to make 3 to 5 pint sized juices per day in the morning and kept them in the refrigerator for Ernest to drink throughout the day.



Plus, the chickens we have in our backyard love the pulp that is left over from the juicing, so nothing goes to waste. Pretty simple, but very effective.



Chickens eating the pulp

Whether you are using freshly made juices to cure a disease or ailment, or simply because you want better health, you cannot argue with the science behind it and the testimonies of those who use this process. It is a good idea to learn about better ways to better health because we all have people in our families and circle of friends that are suffering unnecessarily with diseases that can be cured or at least slowed down, and none of us are getting any younger. So it is up to us to get this information out, since much has been done to keep it out of the mainstream media. If that happened, people might just take it upon themselves to get well and not have a need to go to doctors to have expensive treatments done that will leave their bodies in ruins, or be stuck on some ineffective, liver damaging drug for the rest of their lives. And you can bet that the drug companies are behind a good portion of wanting this information under wraps (you can't watch a program on TV that doesn't have some type drug commercial). So take some time to get educated on ways to better health. Juicing the Gerson way is a very good start to a much better, longer, healthier life. 🍷

[Make a Comment](#) • [Email Link](#)
[Send Letter to Editor](#) • [Save Link](#)

HOMEMADE GOAT CHEESE...

By Donna Hancock

[Make a Comment](#) • [Email Link](#) • [Send Letter to Editor](#) • [Save Link](#)

1. TAKE fresh, filtered goats milk and pour into large, heavy pot.



2. Heat goats milk SLOWLY to about 190-200 degrees F (DO NOT STIR). May take about an hour.



3. Remove from heat. Pour regular, distilled vinegar into heated milk to make it curdle. (Use 1/2 cup vinegar per gallon of goats milk).

4. Stir well (if you think the goats milk has burned a little bit on the bottom, do not scrape spoon on bottom of pan).

5. Cover and let sit for a couple minutes, then strain out curds and put into colander to drain. Get as much liquid out as you can (liquid is the 'whey' as in whey protein, which it has a lot of).



6. There are two options available at this point to make two different type of cheese.

OPTION 1 - TO MAKE A CRUMBLY CHEESE TO SPRINKLY ON SALADS AND ENTREES:

7. Leave curds in colander and cover. Let sit undisturbed in a cool, dry place for 24 hours.

8. After 24 hours, remove curds from colander and chop into pea sized pieces.



9. Mix in seasoning of choice and sea salt thoroughly (4 tsp. salt per 2 1/2 gal milk used)

10. Put seasoned cheese in freezer bags and label with date. Can store in freezer for several months, or in fridge up to 2 weeks.



OPTION 2 - TO MAKE LARGE CHEESE ROUND FOR SLICING:

7. Put hot curds in a bowl and mix in whatever seasonings you wish with a spoon.

8. Spoon warm, seasoned curds into CLEAN, OILED cheese press (so that it is easier for cheese to be removed from press when finished). Press curds down with hands to get it tightly packed, especially around the sides.



9. Put top on cheese press and tighten screw onto frame. Twist handle crank so that it squeezes out excess whey. Rinse press with water to wash away any excess whey.

10. Place cheese press into pan/dish so excess whey has a place to drain out.

11. Cover cheese press with clean cloth or tea towel and put in a cool, dry place for 24 hours.

12. Will need to twist handle crank on press several times so that you will squeeze as much whey out as you can.

13. After 24 hours, remove cheese from press.



14. Elevate cheese round on dish or wooden platform set on clean plate.



14. Cover cheese with lid (leaving a space so that air can circulate around cheese). Put in fridge

Continues on Page 65

Continued from Page 64 - HOMEMADE GOAT CHEESE...



for 1 week, turning cheese round over several times during the week.

14. Remove cheese from fridge after one week, cut, and package as needed. You can use freezer bags and store in freezer for several months, or in fridge for several weeks. If vacuum packed, cheese can last in fridge for several months until opened.



NOTES:

There are other coagulants other than vinegar that will curdle the cheese, such as rennet. If using rennet, the temperature that you will want to



heat the goat's milk to is 110 degrees. There are animal and vegetable rennets.

Invest in a good thermometer that can be stuck down into the pot while milk is being heated so you will get a more correct temperature (if you use a food thermometer that you stick in liquid near the top, you may not get a correct temperature). Having the correct temperature is very important for getting the cheese to curdle for the specific coagulant used.

Make sure your operation is CLEAN. If doing this at home, it isn't necessary to sterilize everything (although it doesn't hurt). Just make sure everything is washed well in hot, soapy water, and that your hands are kept clean throughout the process.

You can use plastic if necessary (bowls, spoons, colanders), but germs can hide in the small scrapes and cracks that plastic can sometimes get and you will be more prone to having problems. If using plastic is your only option, use bleach to sterilize first. 🍷

[HOMEMADE GOAT CHEESE... 1of2](#)



[HOMEMADE GOAT CHEESE... 2of2](#)



[Make a Comment](#) • [Email Link](#) • [Send Letter to Editor](#) • [Save Link](#)

The Case Against Quartzsite

By L.E. Stone

[Make a Comment](#) • [Email Link](#) • [Send Letter to Editor](#) • [Save Link](#)



QUARTZSITE, people say, has it all.

The little town sits -- divided -- on both sides of I-10 between L.A. and Phoenix, the last place to buy fuel before heading off

into the desert where there's almost 150 miles of isolated desert roadway.

And for those travelers headed to Phoenix, it's also the first place they find for fuel and refreshments after driving that same stretch of road as they're leaving California.

With temperatures soaring into the high teens in the summer and a rock and gem show that sizzled during the winter season, it was, locals said, 'a natural.'

That once meant it was 'a natural' in terms of destination.

Today, they're more likely to be talking about various forms of corruption.

Richard Oldham, the 'founding Mayor' of Quartzsite, spent some 65 of his 72 years in this tiny town. He grew up in Quartzsite in the early 1940's when his parents often left him to watch their property there.

The outback in the State of Arizona became his life.

A child, Oldham watched as the women seeking to become the country's first licensed military pilots came to the little town to learn to fly, hoping to become the earliest versions of military fliers and earn for themselves a place in aviation history. It was, he figured, the best way to deal with the isolation of the tiny town 'in the middle of nowhere.'

Licensed to fly by the age of 19, he found a job working in Prescott at an auto dealership. He became the private pilot for his boss, Theo Lamb, the dealership owner there.

Lamb also owned dealerships in Texas and California.

When Oldham was 24, he purchased the Chevrolet dealership in Parker, just 35 miles north of Quartzsite. Although Lamb could not understand his fascination with the area, he supported Oldham's decision. When the opportunity arose to move to California, he still continued keeping an active interest in the La Paz County area, using that location to store vehicles and flying back and forth to California to manage his personal business.

He was more than moderately successful.

As the 1980's began a boom time for Quartzsite, Oldham developed a piece of property he had initially purchased with a partner.

Unable to move that unimproved property on the real estate market, he purchased more property to go with the original parcel of 130 acres, adding another 65 in the hopes that it would sweeten the deal and he could find a buyer. He first built an RV park and then one for mobile homes.

He established a mobile home sales lot and today still runs that business.

"I could not convince anyone to buy that property," Oldham stated. "Quartzsite is a hot and dusty location between what has always been the more popular ones like Palm Springs and Phoenix. It was -- more or less -- the 'white elephant of it's day.'

The problems with Quartzsite, even then, were more than apparent.

It was unincorporated. It needed a water and sewer system. The town drew opportunists and even misfits that were not welcomed with open arms in other places.

The people that came in search of rocks and relics ranged the gamut. A few found gold. Others were content with trading gemstones and other minerals scattered throughout the area with those who brought these same treasures from other parts of the world.

It was a strange combination. Truck stops housed secret gambling facilities and rampant groundwater contamination seemed to happen repeatedly without proper oversight. A resident Constable in the earlier days provided what law enforcement was deemed necessary and later, also in the early 1980's, La Paz County was born.

Oldham was progressively minded. Deciding that the water and sewer issues facing the town were so onerous that they would prevent municipal growth, Oldham flew his private plane around the area during this same period, drawing up the boundaries to establish the perimeters of what would be the Quartzsite township.

At the urging of Oldham and much to the consternation of locals who appreciated the general lawlessness and lack of governmental oversight that Quartzsite seemed to offer, the Quartzsite Chamber of Commerce board eventually set about the business of becoming the town's first councilmen.

Oldham was unanimously appointed to be the town's first Mayor, a position he would win twice more in the town's first elections.

Quartzsite was underway and most were happy with the outcome

In 1987, Oldham's wife, Timmie, who was the model for first his dealership ads and later a company spokesman for other of Oldham's endeavors, was diagnosed with early onset Alzheimer's Disease.

As Oldham slowed his political activities to assist his wife, a new player announced his intentions to join in on Quartzsite's political scene.

Rex Byrd, proud of his history as a Teamster, ran for and won a position on the council. The two had been friends, Oldham providing him access to various pieces of his own earth moving equipment for Byrd's projects -- and he even supported Byrd in his interest in the council.

But the friendship quickly faded when Byrd drilled two wells for Oldham that were not functional. When Oldham complained about the non standard wells, Byrd attempted to sue Oldham in court. The case crumbled as the judge reviewed the facts surrounding the disagreement between the two men and determined Byrd was in error for the failure to produce two functioning wells. He fined Byrd and demanded the wells be com-

Continues on Page 67

Continued from Page 66 - The Case Against Quartzsite

pleted in working order.

In lieu of damages, he also demanded that Byrd pay Oldham's court and defense costs.

Byrd reportedly indicated that this finding cost him \$72,000.00.

Immediately thereafter, Byrd announced his intention to become the fourth Mayor of Quartzsite.

Hosting BBQs and criticizing Oldham using printed materials and a word of mouth campaign, Byrd ran for and won the Mayoral position.

Following Byrd's election, Oldham continued to follow the town's progress and complained that the town's resources were being squandered. Byrd was again vocal in his criticism of Oldham and openly aired his frustration as the situation escalated.

Ultimately, Byrd was named by the Department of Public Safety as a conspirator in a plot to murder Oldham.

Acting in an undercover capacity, an agent stationed in Quartzsite to investigate illegal gun sales, the agent indicated he had been solicited to carry out a contract 'hit' on Oldham.

Interested in making certain that officials would be able to gather indictments against all of the participants in what they described as a conspiracy, the Department of Public Safety orchestrated the staging of a scene intended to convince Oldham's enemies that he had, indeed, been murdered.

Undercover agents took Oldham out into the desert and staged a scene that included placing his 'corpse' under an ironwood tree, hat askew, body posed to appear as though he had, indeed, been murdered. The various agents took an abundance of photographs to ensure the perpetrators would be convinced of his demise.

Oldham, meanwhile, was directed to leave the area and go to California until the 'sting operation' against 'the conspirators' had been carried out.

The coming months were filled with details of the trial that concluded in the conviction of Rex Byrd. The individual that actually paid the money and participated in other elements of the incident pleaded guilty.

After less than a year in prison, this second individual was utilized to bring questions concerning Byrd and Byrd was released. He resumed his position as Mayor of Quartzsite and lost to Patty Bergen in the following election.

Byrd died in December of 2001.

To assume that there is 'a feud' that has extended ten years beyond the death of one of these men is unrealistic to even the most naive.

Instead, a detailed review of the situation and the records available *readily verify* that Oldham's businesses and properties have, indeed, been under a steady barrage of fire from the *existing town council* -- which has necessitated he remain apprised of their actions. Oldham has consistently indicated he has no interest in running for office [the last time he ran was 8 years ago] and that his interests no longer include participating in local politics.

But he, like others in the community, has watched

local property values plummet while property ownership expenses are soaring.

"It's amazing to see the level of interest the town's officials dedicate to trying to convince onlookers that 'a feud' that culminated in a conviction in 1994 [now nearly 20 years ago] is somehow an excuse to continue to intimidate and attack area businesspeople -- even blaming it for the 'political unrest' happening throughout the community," Oldham stated.

"I am not the only person in town that they are attacking -- that needs to be said. There are others -- anyone that opposes their political agendas soon comes under fire from the town's officials. But specifically, in my case, they have attacked my businesses with selective audits and even double taxation. When I defend myself legally with attorneys and provided documented proof of my side of the story, even hiring attorneys to represent my interests -- they have resorted to ridiculous levels of abuse -- even engaging in actual property destruction!"

"When the town indicated my 20+ year old runway at the Main Event property on the edge of town should no longer be in existence -- and I hired a land rights law firm from Phoenix to defend my properly rights -- they sent two graders to tear 'a road' through the runway, *using the town's equipment to destroy personal property while the police chief attended to oversee the destruction.*"

"When I asked for the records to include in my case to show who ordered those graders to come to the Main Event and destroy the runway, I was told there was no record. When I, and others, have used the *Freedom of Information Act* in an attempt to obtain proper documentation, those requests have -- more often than not -- been completely ignored. The town's officials are even now under fire from the State of Arizona Ombudsman's office for ignoring *viable FOIA requests from many of our citizens.*"

"When I have attempted to speak to the Town Manager concerning any issue with my properties, she has used town personnel to return my call with the message, "Have your lawyers call our lawyers."

Then, of course, there is the activities that many deem to be a form of harassment.

"I frequently field calls from my employees telling me that Al Johnson is again on one of my properties taking pictures," Oldham stated. "ADEQ and the County Health Department were called and there was an incredible 'back and forth' when I began asking who reported an infraction. There always seems to be an effort to conceal the facts."

"ADEQ is happy with the state of the properties, as were the county health department inspectors," he said. "They seem to be very aware of what is happening in Quartzsite."

Johnson, a California resident, is reported to have started his 'position' here telling people he's related to Town Manager Alex Taft. This is a far more serious allegation than many people realize.

"He came to me when he first started working in Quartzsite asking me to assist him in learning how to tell if a mobile home is properly set up," Oldham said. "I assisted him at that time hoping that things would improve. However, soon after he became the building inspector, problems mounted."

Continues on Page 68

Continued from Page 67 - The Case Against Quartzsite

Johnson was seen, during a period when the Town Clerk, Karen Norris, was out of town, loading boxes of documents from the Town Hall building into his trunk.

When this was questioned, a written report from Town Manager Alexandra Taft was received stating that 'Johnson was removing documents for recycling.'

Since there is a very large recycling bin within a block of the Town Hall property, this excuse for the removal of town hall documents while Ms. Norris was out of town seems less than plausible.

"Shortly after all of these activities were brought out, I was contacted by Mr. Johnson who began asking questions about a steel building I had moved from one of my properties [Desert Gardens Sales Lot #1] that I had moved to the Main Event West property that I had purchased."

"Johnson indicated that the documents involving the Building Inspection for this move -- handled by the previous Building Inspector, Marc Skoglund, were not in my file," Oldham said.

An interview with Marc Skoglund quickly revealed that Skoglund would willingly stand by his original inspection, the records of which he indicated were 'absolutely in the Oldham files' at the Building Inspector's office at Town Hall. Skoglund also indicated that he would provide this information under oath, if necessary, and guaranteed that he would abide by stipulations of a subpoena and provide his testimony pertinent to the records he had created during his tenure at Quartzsite as the Building Inspector.

Meanwhile, Oldham [and his airport] were singled out to be the subject of more than one Quartzsite Town Council meeting, listed as an agenda item. In the published agenda, they stipulated that they were going to consider a lien against Oldham. This, without any proof whatsoever that the town's allegations against Oldham were even correct.

A similar incident concerning what they said was a right of way through the airport

This, when there had been no proof whatsoever that Oldham could be held liable -- for anything, under any circumstances.

While the council went into executive session to discuss -- with an attorney in a telephonic conference -- the issue, they returned to their seats with no report of their decision.

Finally, Lizarraga stated that they would be issuing citations to Oldham.

And citations there were.

Johnson, promptly issued **9 criminal citations** to Oldham over the erection of the steel building he said had been built without proper permitting. Two weeks later, he issued **another 9** criminal citations.

It was reportedly these criminal citations -- the first batch of which was tossed by the Quartzsite prosecutor, Matt Newman -- that resulted in the firing of Newman.

Newman, a highly regarded attorney with a perfect performance record, was quoted in the Arizona Republic Sunday, July 17, 2011: "I was saying the criminal law is too important to use for political purposes. There were several cases where I said, "No, I'm not going to file criminal complaints."

The second batch of criminal citations is still pending against Oldham. In the period since the town became overtly aggressive towards Oldham, he was audited -- first going backwards from 2007 for five years and then forwards from 2007 for five years in an apparent effort to obtain the highest tax burden possible.

"It doesn't seem to matter to them that the law they're relying on is unconstitutional, has been the subject of recent Congressional testimony and is very likely to be overturned," Oldham stated. "Further, the auditor the town hired -- was a 'third party auditor' in fact -- and that is another issue for which the town is under fire.

"Not only does it appear that they are being selective in their choices for who receives an audit, they're allowing an auditor to present themselves as a 'town employee' when that's not the case. The 'bounty hunter' aspect of it is repulsive to many people and should be discontinued because it provides an incentive and then rewards people for attacking law abiding, tax paying citizens," Oldham concluded.

Those, though, aren't the only laws being broken.

In recent years, Quartzsite has been constantly criticized for what appears to citizens to be overt efforts to quash public comment and/or criticism.

"They would actually tell you to sit down and shut up at council meetings," one woman stated. "It was horrible. You could not make any type of public comment without risking having one of the council publicly humiliate you for saying something they didn't like.

"How are you to manage your business, your property under such an improper and unprofessional atmosphere?" she said.

"I began to understand that there was no way to reasonably deal with people so overtly unreasonable."

Others have echoed similar concerns.

"When Foster took office, things looked like they would change for the better because he was at least willing to talk to people about their concerns," stated Red Gjerdahl, a candidate for council. "But they quickly moved to discredit Foster by whatever means they thought necessary to stop his questions. He could readily see that there was money flowing everywhere and that [Ex-Mayor Steve] Bennett's accusations concerning the monies were more than accurate. There are vast amounts of money the town has 'spent' for which there are no apparent purchases."

"How does this happen?"

The critics of the council's activities are many and seem to come from every economic group.

Travelers have complained that the police were targeting winter visitors. The I-10 corridor within Quartzsite's boundaries also generated a great deal of revenue for a time as Quartzsite's officers were focused on patrolling that area, reportedly under the direction of the [now criminally accused] police chief, Jeff Gilbert.

Those that tried to organize to defend themselves against what they described as a corrupt local government were further targeted, some folding under the financial burden of having to constantly defend themselves and their proper

Continues on Page 69

Continued from Page 68 - The Case Against Quartzsite

ties against the attacks of the council.

The council itself does not seem to be comprised of business people but, instead, a blend of 'cronyism' that is not readily apparent.

All of the council are people that were originally appointed to hold their seats -- but by whom and for what purpose?

It has been said that all of them were elected in the last election to the seats that they were originally appointed to fill. But at least one person -- Larry Pickett -- has indicated that he has solid evidence of problems in that last election.

The councilmen seem to have problems of their own.

The 'now infamous' video of Joe Winslow demanding the removal of publisher Jennifer 'Jade' Jones has brought more questions than answers about Winslow, heard making a comment on the town's audio system just prior to the commencement of a Town Council Meeting about 'machine gunning' his critics in the front row.

Councilman Jerry Lukkasson is heard on the tape, concurring with Winslow's comments.

Lukkasson, who was very involved in an incident in which people were prevented from running for office on the basis of being accused of owing money to the town even responded to a letter from Goldwater Institute pointing out the illegality of such an action by defending the town and their position on the matter -- only to find himself attempting to redeem his tax bill in La Paz County on the morning of the day his own tax liens were to be sold at the county's auction of liens.

Town Councilman Bob Kelly is accused of having used his position to make special deals for his friends on the water and sewer system requirements at a properly called Q Mountain Estates. Under these 'special' accommodations, those people won't be seeing the massive increases in rates that threaten to financially destroy the businesses who have been forced to comply.

Other councilmen are accused of pandering to their friends, violating open meeting laws, harassing those they deem to be their political foes.

The disastrous consequences of these actions and activities might have been avoided had it not been for the Quartzsite 10.

A few weeks before Jones' video was even created, she was attempting to check into what was apparently an arrest, some of the details of which were aired on area scanners.

When she arrived at the scene, she was quickly targeted, she said, for arrest.

Jones has consistently indicated that she is fearful of the Quartzsite police chief and she called the Mayor of Quartzsite, Ed Foster, to be present during whatever was about to transpire.

Jones has since stated that Police Chief Jeff Gilbert initially told her she was not under arrest but then did proceed to have her arrested by his officers.

During the ensuing melee, she says she tossed her keys to Foster, against the direction of the police.

Foster put his foot on the keys on the ground only to find himself charged and arrested many days later as he was about to convene a Town Council session.

"That was the end of the road for the officers in Quartzsite," Foster stated. "They had finally had enough.

Quartzsite's officers submitted a letter indicating a vote of 'No Confidence' in Quartzsite's Chief of Police Jeff Gilbert.

They outlined a variety of both civil and criminal infractions and accused Gilbert of forcing them to use their powers as policemen to target what they say he perceives to be 'his' political enemies.

They also charge that Gilbert was misusing his own powers in an apparent attempt to make certain he and others in Quartzsite remained in control of the town.

So fixated, they said, was Gilbert on the political activities in Quartzsite, that he was virtually not present and even completely incapable of accomplishing those tasks for which he was hired.

Yet, the town council recently extended his contract and increased his pay.

"I have solid evidence that there are checks going to unidentified persons for unspecified reasons," Foster stated. "This has been happening for years and totals millions of dollars in monies that essentially belonged to the taxpayers of the Town of Quartzsite."

"The council is bent on doing whatever they have to do to prevent these documents from being exposed -- and they've been using the police chief to prevent this from happening," he continued.

"It's the money -- it's always the money. When people begin demanding accountability from people who have not -- for at least a decade in this case -- had to provide it, they have a lot to hide," he continued.

"I was elected to uncover what is happening in Quartzsite and they have withdrawn my powers as Mayor, refused to allow me to even be at the Town Hall, targeted and attacked my friends and constituents with every type of harassment and caused Quartzsite to become the poster child for corruption."

"The attorney general's office has just released a preliminary finding that they have violated open meetings laws in the state of Arizona -- and we all know this is but the tip of the iceberg.

We have a most difficult task ahead of us as we delve into just how deep this corruption runs."

"Our policemen did the most difficult job policemen can do -- they policed themselves, they exposed the level of corruption happening in their own department and they have openly declared that they will not only not be a part of it -- they will do all they can to expose it and then root it out."

"When the dust finally settles in Quartzsite, I believe these policemen deserve to be returned to their positions -- with commendations." 🍷

[Make a Comment](#) • [Email Link](#)
[Send Letter to Editor](#) • [Save Link](#)

THE MONTH IN GUNS

By Chip Saunders

[Make a Comment](#) • [Email Link](#) • [Send Letter to Editor](#) • [Save Link](#)



WASHINGTON D.C.

So this month, the unfolding saga of the Bureau of Alcohol, Tobacco, Firearms & Explosives (ATF), but more commonly known as they have been for decades before 9/11 as simply ATF) Operation Fast & Furious continues to unfold,...slowly.

The saga has been more affected of late, however, more by how ATF and their friends in Congress have been trying to deflect attention away from their mistakes (and outright complicity) toward other distraction, with ATF themselves trying very hard to look like they're doing something.



Maryland Democrat Congressman Rep. Elijah Cummings, trying use the “Gunwalker” scandal to somehow justify more federal gun control, and using the excuse that Congress needs to criminalize firearms trafficking to Mexico (which is already prohibited by federal statutes, by the way), introduced legislation to more strictly regulate the gun trade inside the U.S. Apparently, by making the federal gun police even larger and more bureaucratic would somehow solve their issues with providing guns to cartels. Among the provisions sought in the legislation, purchases of more than one semi-automatic rifle at once would be required to be specially reported to the ATF on a form for just such a purpose.

But under pressure from Obama, the ATF isn't waiting for the law to be passed. By regulatory decree, it is already issuing demand letters to all federally licensed firearms dealers that they must do exactly this. They claim there is no need for gun rights advocates to worry that this is gun registration, however, since by law they are now allowed to maintain records of who has bought guns, and the reporting requirement is merely for investigative purposes. Indeed, according to federal law, the Firearm Owners Protection Act, codified as 18 USC §926 Rules and regulations...

“The Attorney General may prescribe only such rules and regulations as are necessary to carry out the provisions of this chapter...

(3)... No such rule or regulation prescribed after the date of the enactment of the Firearm Owners' Protection Act (1986) may require that records required to be maintained under this chapter or any portion of the contents of such records, be recorded at or transferred to a facility owned, managed, or controlled by the United States or any State or any political subdivision thereof, nor that any system of registration of firearms, firearm owners, or firearms transactions or dispositions be established.”

An open and active criminal investigation is one provision under which such records can escape the prohibition listed above. But unfortunately, in a bit of short-sightedness when the legisla-

tion was passed back in 1986, [no penalty for violating the ban of maintaining gun ownership databases by the feds was specified.](#) When these report forms on multiple sales start rolling into ATF field offices on Aug. 14th., they will be reviewed by someone, and they will be stored in federal custody. This will violate 18 USC §926, unless of course, **EVERY** file remains as an **open investigation**. If they don't, then we simply take ATF's word that the records were destroyed? No one digitized them and loaded them on thumb-drive? How can such possibly be **proven**? Even if someone caught ATF with their hand in the cookie jar, without any penalty, would anything happen to those responsible? The answer is no, because the law that is supposed to restrain ATF is toothless, and therefore can hardly said to exist at all.

So what is to stop ATF from pursuing a political agenda and assisting disarmament traitor monkeys in Congress? Apparently not much, and already seems to be happening, as evidenced from emails that have come to light in the hearings that have played out in Washington over the ATF's scandal. Katie Pavlich, assistant editor for www.townhall.com first revealed the “smoking gun” email between ATF officials: Mark R Chait, assistant director for field operations with the ATF, copied ATF deputy assistant director for field operations on an email to William Newell, the special agent in charge (SAC) of the Phoenix Field Division:

“Bill – Can you see if these guns were all purchased from the same FFL and at one time. We are looking at anecdotal cases to support a letter on long gun multiple sales.”



Bill Newell is at the heart of the scandal, as he was the principal director of Fast & Furious from day to day, and has lawyered-up, attempting to delay testifying before Congress.

Interestingly, just this weekend it has become known that Bill McMahon, Assistant Director of ATF, and one of the defenders of Operation Fast & Furious, McMahon in essence received a promotion. ATF's OPRSO (Internal Affairs) is the highest level of integrity review in the Bureau. They have given the keys to that car to a person who has displayed self-admitted incompetence and refused any accountability for Fast and Furious beyond an admission that he did not review reports closely enough on the case. He has no integrity but now he will be judging everyone else's. Plus, he has supervised and protected SAC John Torres for years, one of ATF's biggest criminals. Prepare for the already low esteem of IA to sink deeper regardless of how well Chait props him up.



Continues on Page 71

Continued from Page 70 - THE MONTH IN GUNS

But trying to misdirect everyone's attention from the hearings has been ATF's number one job of late. So desperate at this have they been, that they even have turned on their supposed friends, the FBI, making the claim much like a child would "but he made me do it!"

Testifying before Congress, ATF Director Ken Melson, who has been under pressure to resign, but has thus far refused, said the FBI and DEA kept the ATF "in the dark" about their relationships with the cartel informants. If ATF agents had known of the relationships, the agency might have ended the investigation much earlier, he said.



The question thus has become, **"Did the guns supplied by ATF get bought by funds provided to criminal participant by the FBI and DEA?"** Wouldn't that make the U.S. Government the most effective supplier of guns to cartels, and not the status of U.S. gun laws?" Obviously, there are people in Washington that don't want those questions asked.

And speaking of the government selling guns,... residents of Washington D.C. Who wish to buy one may soon have to do so at Metro P.D. Headquarters. In a twist for the District, which once banned the weapons before its rules were struck down by the Supreme Court, emergency legislation that would make D.C. a licensed firearms dealer is being considered. Under the legislation, gun owners who want to bring handguns into the District would have their guns shipped to government offices to get the stamp of approval to carry them within D.C. borders. D.C. needs the law because the only licensed firearms dealer in the District is temporarily closed for business as of April. That amounts to a de facto ban on handguns, since no one can now legally bring a gun into the District, The Washington Examiner reports.

D.C. hopes to dodge a legal bullet by allowing its only licensed gun dealer to operate out of police headquarters. The city will permit Charles Sykes to use space at the Metropolitan Police Department headquarters, Mayor Vincent Gray said Wednesday. He'll be allowed to set up shop in the tight security offices where guns are registered. It won't be set up like a retailer, officials said. "There won't be any exchange like a regular commercial establishment where you go in and purchase," Deputy Mayor of Public Safety Paul Quander said.



What is interesting about this situation is how it eerily parallels the gun regulation scheme in Mexico. Gun ownership is embodied in the Mexican Constitution (bet you didn't know that), but has become nearly non-existent due

to regulations meant to make it so difficult and expensive that hardly anyone does so. (Legally, at least.) Mexico has only 1 legally operating outlet for guns sold to civilians,...and it is on a military base in Mexico City.

FLORIDA

But not all of the feds' gun problems are in D.C. and the southwest. Virginia O'Brien, Special Agent in Charge at the ATF Tampa Field Division, and formerly SAC at the Phoenix Field Division over Bill Newell (remember him?), ran a gun-running investigation that was walking guns to Honduras using the techniques and tactics identical to Fast and Furious. After leaving the Phoenix office, O'Brien was promoted to the Deputy Assistant Director of ATF, but then stepped down to the position in Tampa.

"From a first person source she is sh*tting herself trying to cover it up," a confidential source has stated.



CALIFORNIA

And speaking of federal guns ending up in the hands of odd persons, it seems nearly 30 military select-fire rifles (also known as "assault rifles" or simply "machineguns") disappeared from Fort Irwin, California 2 weeks ago. Ft. Irwin, home to the U.S. military's Opposition Force (OPFOR) Desert Warfare Training Center, hosts rotating military units to play war games against the 11th Armored Cavalry, who use captured soviet vehicles, equipment, uniforms, weapons and tactics. It is also where U.S. personnel often go to get foreign weapon familiarization training with weapons they may encounter overseas,... like the Russian AK-74s that are missing.



Now usually, when it comes to theft of U.S. gov't property from military facilities, the FBI is the agency to pursue the investigation. Military investigators may head up the task at first, but if it gets handed off to anyone, the FBI is it. If the FBI needs specialty consultation on matters involving weapons, the ATF may be brought in to assist. But it is still an FBI thing. Or at least, it **was**. These are difficult times for ATF, and they need high-profile cases that will rescue their reputation. So,...somehow,...the case of the missing AK-74s from Ft. Irwin is being conducted **entirely** by ATF. Perhaps this is why the public is only now learning of this after 2 weeks,...while a turf battle was fought in D.C. Over who would lead this case?

NEW ORLEANS

During Hurricane Katrina back in 2005, authorities did a lot of things that were not actually within their authorized power to do. Most famously for gun rights advocates, the police... and people deputized by the police who were not trained in law enforcement,...seized firearms from people illegally. But nearly as famous as that conduct, the police engaged in a number of

Continues on Page 72

Continued from Page 71 - THE MONTH IN GUNS

gun battles with people they could not always see. As the crisis wore on, many officers got increasingly quick on the trigger to engage anyone they thought was targeting them. This produced New Orleans' own Mai Lai type massacre, at the Danziger Bridge.



Massacre is probably an inaccurate term here, since it denotes the death of several persons, and at the Danziger Bridge, while 6 people were shot by NOPD officers, only 2 were killed. Yet, the dynamic of tired, under-fire, poorly-trained, poorly-led persons surrounded by unseen dangers in "Indian country" cut off from their normal command structure and on their own was rather similar to what led to the dead villagers in Mai Lai. One of the dead men, after first being wounded by gunfire in the initial opening salvo, ran away from the gunfire. He was chased down and shot in the back from a speeding police car. All the wounded and dead had been unarmed. Testimony was given that, as the officers rolled up on the scene of reported shots fired at officers, they saw people running,...and opened fire on them.

Officer Ignatius Hills said he jumped out of the rental truck after the shooting stopped and scanned the blood-covered bodies on the ground - civilians who had allegedly shot at the police moments earlier - and wondered aloud where their guns were. Sgt. Kenneth Bowen heard him and answered "that he had kicked the guns off the bridge," Hills told jurors in a New Orleans courtroom earlier this month. So began a web of deceit, federal prosecutors say, that stretched for years after the slaying of two civilians by police in the chaotic aftermath of Hurricane Katrina. Four others were injured in the September 2005 shooting. Defense attorneys argue that in the hysteria and trauma following the hurricane and flooding, police were doing their best to keep the peace that day and believed they were being fired upon.

Hills told jurors that he knew immediately that Bowen had not kicked weapons off the bridge. He decided that the shooting was unjustified and officers intended to cover their tracks. He later admitted that he participated in a cover-up after cutting a deal with the government last year. His testimony and that of others who have made plea deals will be crucial in proving the government's case. Lt. Michael Lohman, who also pleaded guilty, told the jury earlier in June that every report filed about the Danziger incident is full of "lies and fabrications."

Detective Jeff Lerhmann also testified how officers later planted guns and even made up false witnesses to cover their own asses. When it was obvious that the civilians' lack of weapons was

a problem, he said, they "fixed" it by planting a gun.

"We got one from Archie's house," he said.

Then, when the investigators entered Kaufman's Colt revolver into evidence, he said they took another step: They reported they had confiscated the weapon from Lance Madison, whose brother was killed at the scene. And they arrested him and charged him with attempted murder of police officers.

Lehrmann said after attributing the planted revolver to Madison, Archie Kaufman, who was the lead officer orchestrating the cover-up, "was not happy" to learn that Madison had no criminal record.

"These are big charges against a man who's never been arrested," Lehrmann said on the witness stand.

Lehrmann said he and Kaufman also made up two eyewitnesses: Lakeisha Smith, who supposedly stated she saw Ronald Madison reach into his waistband for something before being shot, and James Youngman, whose statement said he saw young men shoot at police and then flee over the Danziger Bridge.

Neither Smith nor Youngman exist, Lehrmann said.

"The lies changed whenever we needed to change them," Lehrmann said at one point, in reference to filing many false reports. "It was part of the fun."

The trial is still ongoing and is expected to run into next month.

TEXAS

And remember last month how we discussed Adam Gadahn, "The American Al Qaida" muslim convert California dude who put out a video call, in english, for muslims in America to go buy guns and start shooting people? Well, it seems one U.S. Army soldier of islamic faith intended to take up that challenge. Pfc. Nasser Abdo, who had previously already gained notoriety for applying for Conscientious Objector status to prevent being deployed to Iraq or Afghanistan, was arrested for supposedly plotting to conduct some sort of attack at Ft. Hood, Texas. The same installation where Maj. Nadal Hasan killed 13 soldiers and wounded 32 others. Amazingly, Abdo was foiled for attempting to buy his weapons from the very same store in Killeen where Hasan bought his weapons. The store clerk was suspicious when Abdo bought 8 pounds of gun powder, but asked several questions about the powder that indicated he had no idea of its common use by sportsmen in manufacturing their own ammunition, or how to do so. His alertness aroused, the clerk called the police, who followed up.

According to Killeen Police, Abdo admitted his intention to commit a terror act. The target of Abdo's plot was to be a restaurant outside the Ft. Hood base frequented by base members, a senior law enforcement source told FOX News Channel. The attack was to involve at least one bomb blast followed by a shooting attack.

Killeen seems to just not be able to escape crazy shooters. Back in 1991, a crazed man drove his truck into a Luby's Cafeteria in Killeen and opened fire on the customers, killing 23 people and wounding 20. The end result, years later in

Continues on Page 73

Continued from Page 72 - THE MONTH IN GUNS

1995, was Texas finally passing a legal manner for Texans to carry weapons to defend themselves. This was due primarily to the efforts of Suzanna Gratia-Hupp, who was there and watched her parents die because she had abided by the law and left her purse with her gun in it in her car. She ran for the Texas state legislature, principally to rectify stupid disarmament laws like the one she felt obliged to follow that day and which killed her mom and dad.

Then of course, Maj. Hasan did his deed back in 2009.

No word yet from Adam Gadahn as to his opinion on this latest event.

OREGON

Also recall how last month we told you about the currently hot issue of possession of guns while also a medical marijuana patient. I had described how it had been settled in Oregon and Rhode Island that having a MM card was not sufficient grounds to deny a Concealed Carry Permit to a citizen. But there are some very brain-washed cops who can't seem to accept that, and the Oregon Sheriff who first tried to deny an Oregon woman her CCW permit due to being a Medical Marijuana Card holder is appealing his being rebuffed by all Oregon courts to the U.S. Supreme Court.

From Bloomberg Businessweek: "Jackson County Sheriff Mike Winters has argued that issuing the license would violate federal law, specifically the Gun Control Act of 1968. That argument was rejected by a trial court, the Oregon Court of Appeals and the Oregon Supreme Court in rulings that say state law on concealed handgun permits does not pre-empt federal law. Cynthia Willis acknowledged using medical marijuana when she filed her permit application with Winters in 2008, setting off the legal battle. She was issued a concealed handgun license after the sheriff lost in the Oregon Court of Appeals.

Ryan Kirchoff, an attorney for Jackson County, said the Gun Control Act is designed to keep guns out of the hands of people Congress considered potentially dangerous or irresponsible, such as those who use a controlled substance.



Because marijuana is a controlled substance, the county argues gun ownership would be barred under the Gun Control Act, he said. But the state statute concerning concealed weapons doesn't explicitly address it.

Leland Berger, who represents Willis, said judges in three different Oregon courts have already concluded that the federal law does not excuse sheriffs from issuing concealed weapons permits to people who hold medical marijuana cards and otherwise qualify.

"How many judges do we need to rule on this?" Berger said.

The petition Kirchoff filed with the U.S. Supreme Court makes a point of pressing for clarity in resolving conflicting state and federal laws.

"As this case demonstrates, the mounting constitutional and political tension between the states and the federal government over medical marijuana has expanded into the intersection of federal and state firearms regulation," the petition states.

But the likelihood a case will be taken under review is slim. Of the 10,000 cases sent to the U.S. Supreme Court in a given year, only about 200 are heard."

ARIZONA

And the petty tyrant fiefdom of Quartzite hissy fit is finally getting noticed by higher authorities, but it is also now getting even further out of hand, with corrupt council members demanding the seizure of guns from political opponents and banning of their possession. And of course, they have found some lackey judge to issue such an order.

From World Net Daily:

Town Councilman Joe Winslow has prompted the seizure of guns from local gem dealer and online entrepreneur Michael Roth because Roth allegedly glared at the councilman, blocked his entrance to Town Hall and called him a "turd."

Winslow told Slaughter what he wanted was that Roth and others with similar views "not be allowed to walk around armed. To me, I'm not a psychologist or psychiatrist, but I have been diagnosed with PTSD (post-traumatic stress disorder) ... that's what I'm concerned with, that he's gonna get so far into my personal space that I'm gonna react without thinking. I'm not making threats or anything like that. I'm not proud of that, but that's the way I am."

Winslow said he has been flooded with several hundred emails from Americans not happy about his demand for the removal of Jones from speaking, as he called her "disruptive."

"They're contacting people all over the country with similar political beliefs and that's why we had to declare a state of emergency, and Mr. Roth is involved in that," Winslow said.

"I don't like firearms," he said. "I have nothing against anyone who wants to own a gun for protection, hunting, recreation, whatever, that's their business. But you bring the two things together – the fixed-minded people who for whatever reason are aggressive and confrontational by nature and bring in firearms and it's a bad combination. As far as name-calling goes, that's sophomoric. I just ignore it."

Ironically, despite Winslow's self-expressed aversion to firearms and desire to confiscate Roth's weapons, the councilman admitted he had recently gone gun shopping for himself.

"I felt it necessary for me to go out and purchase a gun, and I did," Winslow said. "I went out and bought a 12-gauge shotgun. I don't like it. I don't like being in that position."



So if you follow the logic here; [Councilman Winslow](#) wants citizen Roth disarmed because Winslow is afraid that Winslow might over-react due to his own PTSD issues and harm Roth.

Continues on Page 74

Continued from Page 73 - THE MONTH IN GUNS

And apparently, he wants free reign to do this without being shot by Roth, who understandably would likely want to protect himself from the brand new shotgun Winslow just bought,... bought, apparently, in anticipation of flipping out and attacking someone like Roth.

Um,...okaaaaaaaaaaaaay. Can we all say “arrogant sumbitch with kingly delusions”?

The order for Roth to surrender his weapons to the local police was issued by Justice of the Peace Karen Slaughter, herself a former sheriff's deputy who won a popular election to her position and has no formal legal training. If anything, it sounds like Winslow made the case for **HIM** to be disarmed. Why hasn't the JP ordered **HIM** to give up his shotgun?

Quartzite is one f**ked up town!!!

NORWAY

And of course, we could not possibly neglect to mention Norway, and the terrorist Anders Behring Breivik, who bombed the Parliament square in Oslo and killed over 80 children and others at a nearby summer camp retreat. As most know, mass shootings of that sort are incredibly rare in Europe, and the Nordic countries in particular. Yet, gun ownership there is rather high by European standards. Gun ownership in Norway is nearly as common as it is in the United States, as hunting is a popular activity there. The types of weapons are rather different, with high-capacity auto-loading types of weapons being somewhat scarce,...but available none the less. As has been discussed in the news a fair amount, Breivik acquired all his weaponry legally; going through all the proper channels and fulfilling all the requirements for each and ev-



ery weapon acquired. He complied with (and in the end, defeated) considerably more gun control regulation than most Americans will ever have to deal with. Gun control measures that have been the pride of Europe's political and administrative types, and upon which they have claimed for years were responsible for the relative peace and tranquility that is very rarely disturbed by gun violence.

Gun control measures they always waved in America's face and said we should copy. Gun control measures that so completely and utterly proved themselves useless on that tragic day. Worse than useless, actually. Lethal, deadly, complicit,...evil.

It has been the predictable and expected response in Europe whenever gun violence breaks out on any scale larger than a few people, to say there ought to be more gun control and weapons made even harder to acquire or banned completely. And there is some of that going on in politically “progressive” Norway. But in an unusual moment of clarity and honesty in the debate over weapon ownership in Europe, many Norwegians are coming to the opinion that perhaps all this gun regulation is ineffective and pointless. Some even (gasp) speak of how gun control simply made the campground a giant victim disarmament zone, guaranteeing the wolf Breivik would have nothing but penned in sheep to deal with, and no sheepdog to worry about pulling out his own weapon and stopping the rabid wolf.

Indeed, with all the hunting rifles in Norway, why haven't there been sniper attacks and such? The answer, quite obviously, is that the mere presence of weapons doesn't make someone act murderously. They must choose to. But once they choose to, like Breivik, all that stands between them and a body count is their level of determination and ability to be creative in their mayhem. Indeed, some Norwegians are asking, would it really be so bad if trusted stable citizens were able to have the ability to exercise the option of having a discreetly carried weapon to protect themselves and/or the community in the rare event of something like this happening again? While such reasoning is new and strange to Norwegians, and those opposed to such ideas predictably attempt to shout down such voices of intelligent inquiry, interest in the question is not going away. 🍷

[Make a Comment](#) • [Email Link](#)
[Send Letter to Editor](#) • [Save Link](#)

Real Gardens for Real People in Sun City, Arizona - 03/12/11

[Make a Comment](#) • [Email Link](#) • [Send Letter to Editor](#) • [Save Link](#)

Part 1



Part 2



Part 3



Part 4



[Make a Comment](#) • [Email Link](#) • [Send Letter to Editor](#) • [Save Link](#)

Wonder Soil

[Make a Comment](#) • [Email Link](#) • [Send Letter to Editor](#) • [Save Link](#)



EXPANDING POTTING MIXES



WONDER SOIL 3035 S. Highland Dr. Las Vegas, NV 89109
Ph: (702) 360-5800 Fax: (702) 733-6832
www.wondersoil.com

All products here within protected by Wonder Soil U.S Patents and other pending patents



00:04 / 10:14 360p

Continues on Page 77

Continued from Page 76 - Wonder Soil

Wonder Soil Lawn Seeding



Rooting Success



Scotts EZ Seed (left) vs. Patented Wonder Soil Reground (Right)



Day: 5



Day: 10

Scotts Miracle Grow, a company whose sales are two to three billion a year recently took our patented product, copied it and manufactured it in the biggest launch of their history, selling over 100 million the first year. Currently, we are in the middle of a patent infringement lawsuit against them. Recently, another leading seed company has also instituted an infringement case against them for stealing their patented seed coating technology. Like I said, Wonder Soil is a small business with a huge heart and a mission to create, but that shouldn't be taken as a sign of weakness. Truly a case of David vs. Goliath, and we all know how that one ended!



Wonder Soil
Expanding Potting & Planting Mixes

Tomorrows Potting Soil Today

- WONDER SOIL is an earth friendly complete potting and planting solution for both the novice and professional growers alike.
- We manufacture seven sizes of wafers to accommodate multiple gardening needs from seed starting cells, pots, planters and raised beds to lawn care and hydroponics. Our smaller wafers are also great for boosting existing tired soil.
- Wonder Soil incorporates the finest ingredients to deliver the best results. Since our wafers are dry, we are able to incorporate nutrients and amendments that can't be mixed in conventional bagged soils.
- Wonder Soil is packed with nutrients that don't start activating until the wafers are expanded with water. This guarantees that the soil you're getting is in its richest form.



The Wonder Soil Difference:

- Reduce Watering Needs Up To 50%
- Stronger, Larger, Healthier Root System
- Faster Germination Saves 90% Freight



Wonder Soil®



Loose Soil

[Make a Comment](#) • [Email Link](#) • [Send Letter to Editor](#) • [Save Link](#)

“22 Reasons” A Testimonial about Wonder Soil

[Make a Comment](#) • [Email Link](#) • [Send Letter to Editor](#) • [Save Link](#)

"WONDER Soil is by far the best soil amending product on the market today! Its value is unmatched by any single or multiple soil amendment being sold today. Plus Wonder Soil reduces the amount of watering and application of fertilizer to the garden over the entire growing season by 40% or more ... Comparing Wonder Soil to Jiffy Mix and Redi-earth, the two leading seed starting mixes on the market today, is easy to do. Wonder Soil is by far the best value of the three ... There are several other tests that I could put Wonder Soil through; however, I don't feel the need to do them. Wonder Soil has proven to me that it is the best product on the market. **Bar None.**

I could write a book on this product so what I will do is to give you some general, yet very important facts that you should know about this product:

1. The pH of Wonder Soil is consistent from brick to brick, brick to wafer, and from wafer to wafer
2. It produces a soil with a perfect balance of water to air ratio
3. It is perfectly sterile and safe around children and pets
4. It can hold over 7 times its weight in water
5. It is 100% organic
6. It is 100% biodegradable
7. It produces a higher termination of seeds
8. It produces a stronger seedling with a larger root system
9. It produces healthier transplants and potted crops
10. Cuttings root faster in Wonder Soil, resulting in saleable plants faster
11. It can be used as a seed starting, transplanting, potting and container mix as is
12. It can be used on more than 95% of all

plant material including vegetable, herb, annual, biennial and perennial flowers, potted flowers, cacti, succulents, and some forms of orchids (finer rooted)

13. It can be used on all tropical material as well as all varieties of ferns and vines
14. It can be used on most nursery stock (straight)
15. This product cuts watering and fertilizing costs by up to 50% or more
16. When you buy Wonder Soil, you are buying 100% soil, not soil mixes that have 45-60% fillers
17. This product doesn't crust over when drying out, like soil mixes tend to do
18. This product maintains its unique open texture unlike other soil mixes
19. This product is lightweight, clean, easy to use, and easy to wet
20. Dollar for dollar spent for Wonder Soil vs. any other soil mixes, Wonder Soil is by far the best value for the buck spent
21. Wonder Soil eliminates plant loss due to root and crown rot diseases
22. Wonder Soil produces plants that have a much longer shelf life than any other product on the market today

Today, you growers have an opportunity that I never had, until last year. You have the opportunity to buy and use 'the one product that does it all.' If you truly care about the quality of plant material you raise then Wonder Soil is the only product for you. **Wonder Soil is the 'Rolls Royce' of growing media."** 

Your Favorite Fan

Anthony Valiante

Professional Commercial Grower for over 50 years!

[Make a Comment](#) • [Email Link](#)
[Send Letter to Editor](#) • [Save Link](#)

4409 -- FRUIT POLICE SHOWDOWN - Introduction

[Make a Comment](#) • [Email Link](#) • [Send Letter to Editor](#) • [Save Link](#)

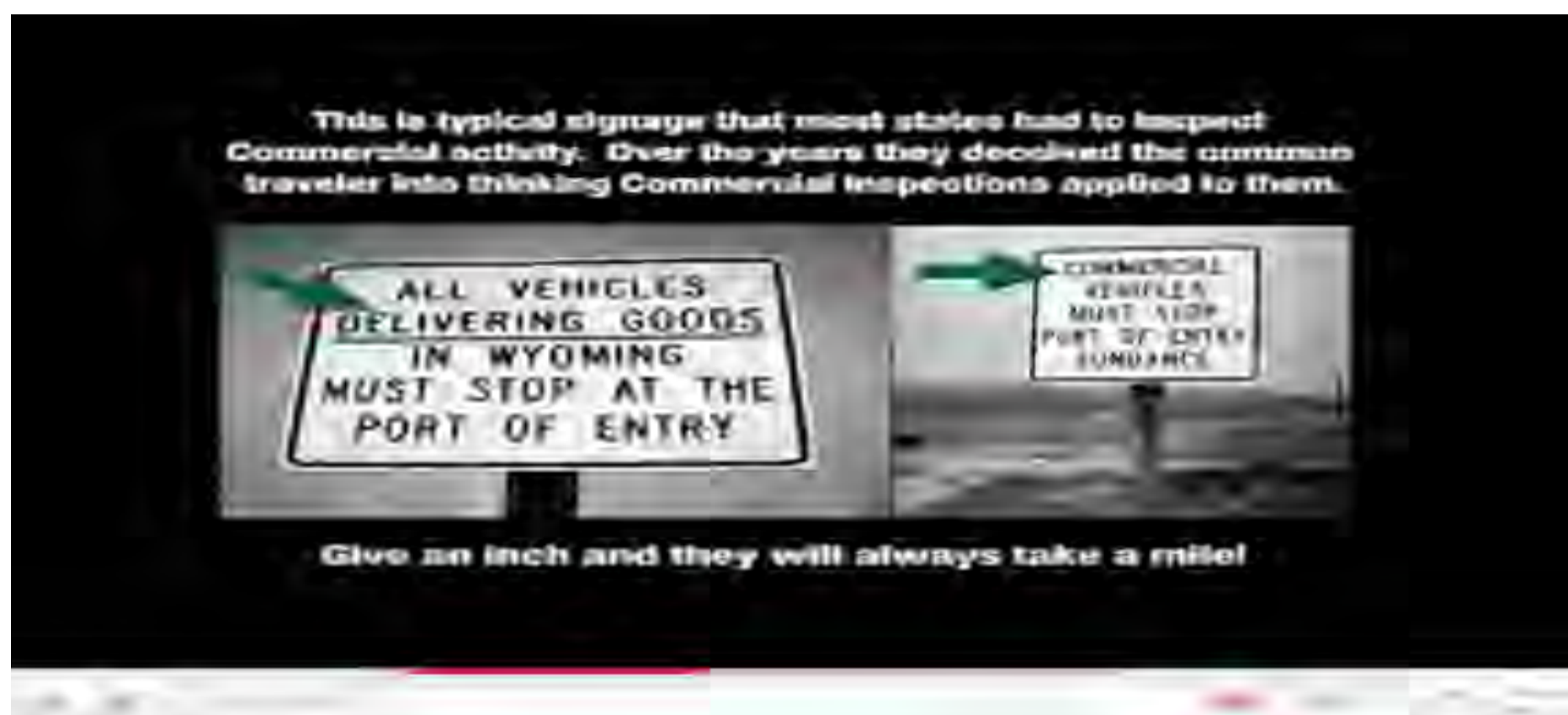

4409 -- FRUIT NAZI SHOWDOWN - Part 1



4409 -- FRUIT NAZI SHOWDOWN - Part 2



4409 -- FRUIT NAZI SHOWDOWN - Part 3



[Make a Comment](#) • [Email Link](#) • [Send Letter to Editor](#) • [Save Link](#)

4409

CONFRONTING PIRATES  EXPOSING HIPOCRISY

WWW.FORMULA4409.COM

As seen on YouTube.com/RP4409

LASER GRAFFITI ACTIVISIM

By Bill Domenico

[Make a Comment](#) • [Email Link](#) • [Send Letter to Editor](#) • [Save Link](#)

LASER *Graffiti* ACTIVISIM

Build a portable laser graphics projector.



USB Controlled Laser Graphics Projector.
Provides an opportunity to "reach out" with your message.
Property friendly guerrilla graffiti is a reality.

Learn what is required to construct your own system.

Continues on Page 81

Continued from Page 80 - LASER GRAFFITI ACTIVISIM



WHAT DETAILS WILL BE REVEALED?

The purpose of this article is to give an overview of what is required to construct your own laser graphics projector. I would consider this build an intermediate to advanced level project. You will need to be capable with both mechanical and electrical / electronic construction methods and techniques. This article is not intended to provide step by step instructions but rather, block level explanations pointing you in the proper direction to achieve a similar end result. Please note: this projector took about three days to build. This is my third projector build. Your results may vary.

SO LET'S TAKE A LOOK INSIDE SHALL WE?

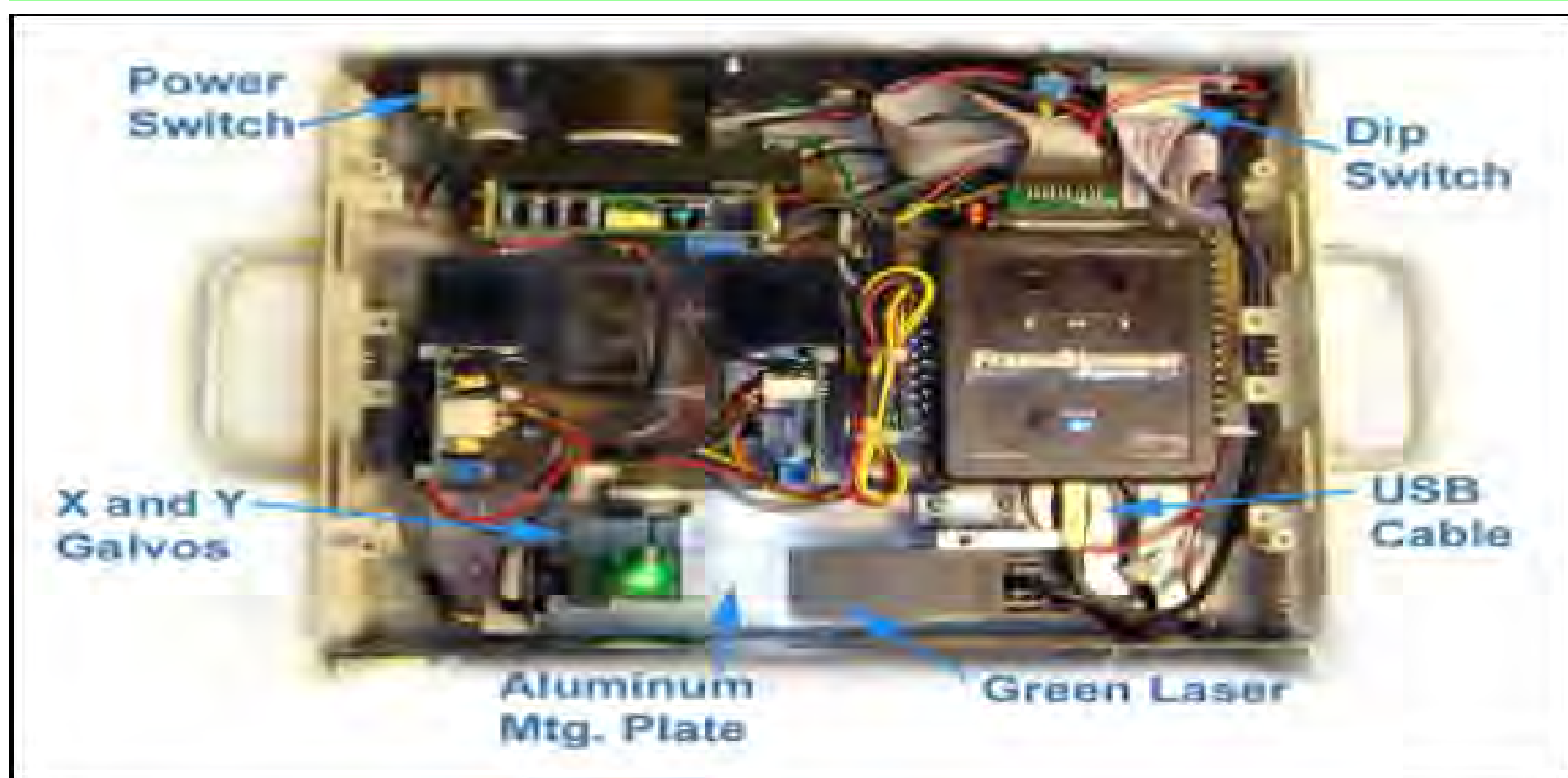

Continues on Page 82

Continued from Page 81 - LASER GRAFFITI ACTIVISIM



WHAT'S IN THE BOX?

The photo above shows the cover removed and the main components labeled. Parts placement is not critical. I would suggest a larger enclosure for first time builders as this build was a little tight. A quick operating description is in order. The 532nm green laser projects a beam onto the lower x-axis galvo mirror. This mirror is at a 45 degree angle to the beam and reflects the beam to the upper y-axis galvo mirror. The upper mirror is also at 45 degrees which “turns” the beam and projects it out of the enclosure. The mirrors are low mass, highly reflective and capable of being positioned by the galvos at up to 30,000 points per second. (30K PPS) The galvos are controlled by the X and Y axis drivers. They receive their signals from the DAC (digital to analog converter) and provide a precise and repeatable voltage to the galvos. During scanning the DAC also turns the laser on and off as required in order to eliminate stray lines between characters. This is called “blinking” and is handled in software. The DAC receives its commands via USB from the laser software running on your computer. You simply type text into the GUI and click start. The galvos will move as required to create the text. Your message can now be seen several hundred feet away. It’s that simple!

SOME CONSTRUCTION CONSIDERATIONS



Continues on Page 83

Continued from Page 82 - LASER GRAFFITI ACTIVISIM

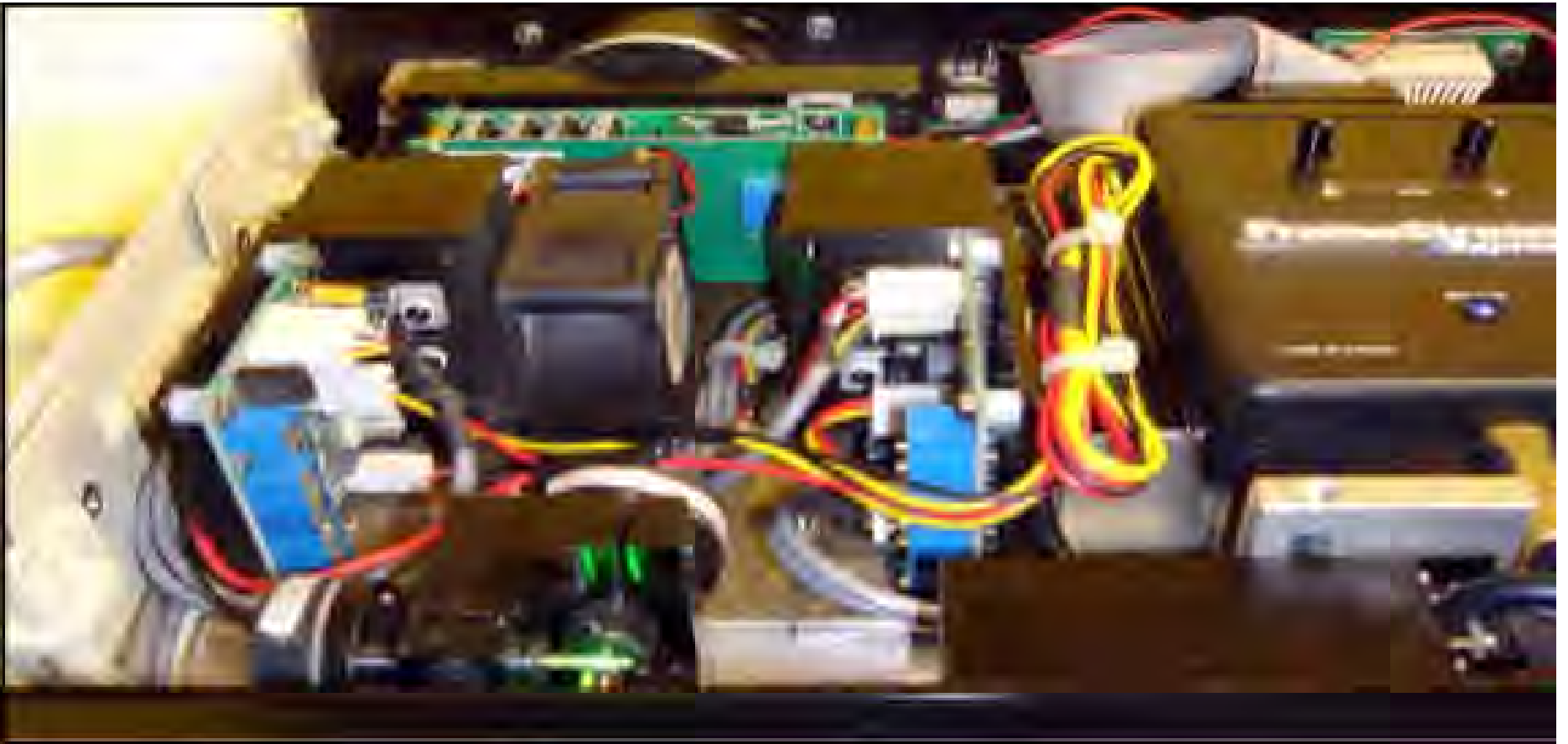

GET RID of THE HEAT.

The enemy of solid state lasers and electronics in general is excess heat. All these components stuffed into a compact enclosure generates significant heat. How warm does your laptop or desktop computer become? Fans and ventilation solve this problem. There are three fans used in this project. Two are shown an the previous photos. (Laser power supply and galvo drivers) The third is part of the laser head. Do not skimp on the fans. You will be very unhappy with the early demise of your projector. Remember whatever volume of air the fans are capable of moving must pass through openings in the enclosure. Appropriately sized for the required volume. In short, don't put a thee inch fan behind a 2 inch opening. Mounting the components on an aluminum base plate goes a long way to help with distributing and dissipating unwanted heat.

MECHANICAL CONSIDERATIONS



Continues on Page 84

Continued from Page 83 - LASER GRAFFITI ACTIVISIM



THIS THING NEEDS TO BE RUGGED!

Be sure to use fasteners sized appropriately for the task. Tighten all mounting hardware securely. Don't forget to include a tripod socket on the bottom. This is a delicate optical instrument. Handle accordingly.

WHAT YOU WILL NEED and WHERE to GET IT.

<u>ITEM</u>	<u>DESCRIPTION</u>	<u>P/N</u>	<u>PRICE</u>
1.	Enclosure:	PAC TEC, CL400	\$51
http://www.pactecenclosures.com/product-detail.php?productid=55&seriesid=44&classid=26			
2.	DAC	FRAME STREAMER 2.0	\$200
3.	LASER SOFTWARE	NLS 1.7	Free
Hardware, http://www.ctrnd.com/NormLaserShow/FSX20.htm			
Software, http://www.ctrnd.com/NormLaserShow/Downloads.htm			
4.	GREEN LASER, 200mW	Meierlight or Equivalent	\$288
http://cgi.ebay.com/200mw-532nm-green-laser-Diode-ANALOG-lightshows-/170655868533?pt=LH_DefaultDomain_2&hash=item27bbe1e675			
5.	GALVO KIT, 30K	Space-LAS	\$244
Includes: X & Y Galvos, mount and Drivers, show card, 24VDC power supply, cables			
http://cgi.ebay.com/laser-scanner-system-30K-20-Max-50kpps-show-card-/300580231627?pt=LH_DefaultDomain_0&hash=item45fbfa59cb			
6.	Misc. Hardware, Including: Aluminum plate, laser mounting bracket, fasteners, handles, fans, switches, wire etc.		

SAFETY CONSIDERATIONS and REGULATORY NOTICE

WARNING: DO NOT SHINE LASER AT AIRCRAFT, MOTOR VEHICLES, BOATS OR LAW ENFORCEMENT!

Laser products described in this article are considered "OEM" components and the purchaser is responsible for properly assembling and installing the components into a finished product that, if entered into commerce, is in compliance with all laws and regulations. For additional information about regulatory compliance, visit the FDA website at <http://www.fda.gov/cdrh>.

That being said. **RON PAUL REVOLUTION 2012**

[LASER TEXT PROJECTOR, CHECKPOINT WARNING !](#)



[Make a Comment](#) • [Email Link](#) • [Send Letter to Editor](#) • [Save Link](#)

Publisher's Backpage

[Make a Comment](#) • [Email Link](#) • [Send Letter to Editor](#) • [Save Link](#)



WOW! Another great edition with lots of quality information.

The Month of September and October are already in the planning stages. We are simultaneously working on the issues of "Raising Generation Next" (Homeschooling, Apprenticeships, Physical Conditioning, Healthcare and Nutrition for Children etc.) / "Alternative Medicine" (Nutrition, Far Eastern Medicine, High Technology, Homegrown Plants and Herbs etc.)

Suggestions about what you would like covered in these areas are very welcome and ideas for future issues are being discussed right now. I would also like to encourage you to suggest books, movies, video clips, music and articles that you think should be shared. It is very simple for us to list such things as suggested material like we demonstrated in our July Edition.

FreedomsPhoenix traffic is increasing rapidly and we are very mindful of the role we play in the battle to free as many minds as possible. Subscribers are encouraged to forward the Enhanced PDF files of the magazine via email to as many people as possible. This will be the only way that a non-subscriber will get the eZine, ... from a subscriber that has the access to download it. Subscribers are able to read the articles in FreedomsPhoenix in the traditional format (one article at a time) and to download the Digital Device files directly from our servers. Subscribers are the only ones that are able to in-

terface with the articles from the eZine or the Site to make Comments, Email Links to friends, write Letters to the Editor or 'Save to your Personal Favorites'. These features are detailed in our latest [Video Tutorial](#)

After watching the [Freedoms Phoenix Video Tutorial](#) you'll start to understand just how powerful Freedoms Phoenix is as a tool to enhance your own personal freedom and that of your friends and family (and the rest of the planet while you are at it... did you know that FreedomsPhoenix is translated into 39 languages?... the Tutorial demonstrates this feature).

I'm very excited about this new medium and I am very happy to have been able to offer this eZine from the beginning of the Tablet BOOM that is coming/[HERE](#). 

Ernest Hancock

Publisher: FreedomsPhoenix.com

[Make a Comment](#) • [Email Link](#)
[Send Letter to Editor](#) • [Save Link](#)



FREEDOM'S Phoenix
Reigniting the Flames of Freedom
FreedomsPhoenix.com
Uncovering the Secrets & Exposing the Lies

www.FreedomSummit.com

FREEDOM SUMMIT Phoenix Arizona
"WHERE THE GREAT MINDS OF THE MODERN FREEDOM MOVEMENT COME TOGETHER"

FAST SPEAKERS: JACOB G. HORNBERGER - DON BOURBONFAUX - ROBERT A. LEVY - BUTLER D. SHAFER - VIN SUPRYNOWICZ - CLINT BOLICK - KATHERINE ALBRECHT - JAMES BOVARD - NATHANIEL BRANDEN - RON PAUL - PETER D. SCHIFF - GEORGE H. SMITH - EDWARD STRINEHAM - ALAN SOCK - DOUG LADDY - CHARLES COYETTE - JUSTIN RAIMONDO - MARY RUWART - KEN SCHOELLAND - CLAIRE WOLFE - RICHARD BOODIE - HARRY BROWN - HANS-HERMANN HOPPE - ERNEST HANCOCK - BOSTON T. PARTY - MARC VICTOR - DONALD 'MAC' MACPHERSON - RICHARD MORRIS - WALTER BECKE - LEW ROCKWELL - JOHN FIDGLEY - LARRY PRATT - SHARON HARRIS - LOUIS JAMES - JOHN BUTERICK - L. NEIL FAITH - MARSHALL FRITZ - DR. STEVEN GREER - CHRISTOPHER NEWARD - NAKIM KWIASNIEWSKI - JANE SHAFER - SUNNY MANAYILLOLA - DR. BRIAN HOWE - DAVID D. FRIEDMAN - SEBASTIAN BROWN - ADAM KOESEN - TUD BUBBALL - JOEL BRUSHEN - JOHN TAYLOR SATTO - JEFFREY A. JONGER - DAN BARBER - JAMES P. GRAY - MARC STEVENS - WILLIAM BUFFETT - TADDTY HORTON - LAWRENCE W. (LARRY) REED - STEPHAN MOLYNEUX - FORDAN PAGE - THE CARTSIDE FAMILY BAND